

---

**LIGHTING BEST PRACTICES SERIES**

Developed by the  
California Lighting Technology Center, UC Davis

**2019**

# **NONRESIDENTIAL LIGHTING AND ELECTRICAL POWER DISTRIBUTION**

A guide to meeting or exceeding  
California's 2019 Building Energy Efficiency Standards





© 2019, Regents of the University of California, Davis campus,  
California Lighting Technology Center

**GUIDE PREPARED BY:**

California Lighting Technology Center (CLTC)  
University of California, Davis  
633 Pena Drive  
Davis, CA 95618  
cltc.ucdavis.edu

**PROJECT PARTNERS:**

California Energy Commission  
Energy Code Ace

**AUTHORS:**

Nicole Hathaway, LC  
Adrian Ang, Graphic Designer  
Michael Siminovitch, PhD



**ACKNOWLEDGMENTS:**

The project team acknowledges all contributions to this Guide, including the sponsor (Energy Code Ace), reviewers (CEC), the authors (CLTC) and UC Davis for their continuing support.

This program is funded by California utility customers under the auspices of the California Public Utilities Commission and in support of the California Energy Commission.

© 2019 Pacific Gas and Electric Company, San Diego Gas and Electric, Southern California Gas Company and Southern California Edison. All rights reserved, except that this document may be used, copied and distributed without modification.

PG&E, SDG&E, SoCalGas and SCE — nor any of their employees — makes any warranty, express or implied; or assumes any legal liability or responsibility for the accuracy, completeness or usefulness of any data, information, method, product, policy or process disclosed in this document; or represents that its use will not infringe any privately-owned rights including, but not limited to, patents, trademarks or copyrights.





## CONTENTS

---

### 1 INTRODUCTION

The Benefits of Efficiency .....	5
About this Guide .....	7
New in 2019: An Overview of Updates .....	9
The Compliance Process .....	10
Compliance Documents .....	12
Finding Compliant Products .....	14

### 4 COMPLIANCE REQUIREMENTS

Navigating the Energy Code: Lighting Requirements .....	34
Mandatory Requirements for Indoor Lighting .....	36
Mandatory Requirements for Outdoor Lighting .....	48
Mandatory Requirements for Electrical Power Distribution Systems .....	56

### 2 CONCEPTS AND PRINCIPLES

Layers of Light .....	17
Light Output, Efficacy and Life .....	18
Color Characteristics .....	20

Performance Approach .....	59
Prescriptive Approach for Indoor Lighting .....	59
Prescriptive Approach for Outdoor Lighting .....	76
Sign Lighting .....	83
Additions, Alterations and Repairs .....	84

### 3 TECHNOLOGY, SYSTEMS AND COMPLIANCE STRATEGIES

Choosing the Right Light .....	23
Light Sources .....	24
Control Strategies .....	27
Lighting Control System Architectures .....	30

### 5 REQUIREMENTS AND RECOMMENDATIONS

Designing to the Energy Code .....	89
Applying Requirements for Office Lighting .....	90

### 6 APPENDIX

Glossary .....	105
Tables .....	110
Resources .....	116





## CHAPTER 1

# INTRODUCTION

## THE BENEFITS OF EFFICIENCY

Energy-efficient nonresidential buildings lead to both environmental benefits and cost savings. The lighting requirements of California's Title 24, Part 6 Building Energy Efficiency Standards (Energy Code) aim to reduce energy use and demand while maintaining high-quality lighting.

Today's commercial buildings consume 19% of U.S. energy, according to the Department of Energy's Office of Energy Efficiency & Renewable Energy.

Improving the energy efficiency of lighting systems has a large potential for energy savings for new construction and existing buildings undergoing retrofits. A significant fraction of that potential savings must come from inclusion of lighting controls, such as occupancy, daylighting, institutional tuning, automated demand response and personal controls.<sup>1</sup>

While energy efficiency is a priority in today's lighting design practice, so are occupant comfort, health and wellness. A successful lighting design balances these objectives.



**2019**  
BUILDING ENERGY EFFICIENCY  
STANDARDS FOR RESIDENTIAL  
AND NONRESIDENTIAL  
BUILDINGS

**CALIFORNIA'S TITLE 24, PART 6  
BUILDING ENERGY EFFICIENCY STANDARDS  
(ENERGY CODE)**  
[www.energy.ca.gov/2018publications/CEC-400-2018-020/CEC-400-2018-020-CMF.pdf](http://www.energy.ca.gov/2018publications/CEC-400-2018-020/CEC-400-2018-020-CMF.pdf)

*California's Energy Code is updated on an approximately three-year cycle. The 2019 Energy Code improves upon the 2016 Energy Code for New Construction, Additions and Alterations to residential and nonresidential buildings.*

*The 2019 Energy Code is effective starting on January 1, 2020.*

<sup>1</sup> Williams, A., Atkinson, B., Garbesi, K., Rubinstein, F., & Page, E. 2013. Quantifying National Energy Savings Potential of Lighting Controls in Commercial Buildings. Lawrence Berkeley National Lab.(LBNL).



## OCCUPANT COMFORT

Factors to consider in lighting design include human needs, like visibility, safety and comfort; and environmental and economic issues, such as energy, equipment costs and sustainability. Additionally, how well the lighting complements the building design must be considered. A successful lighting design utilizes the right equipment to maximize visual comfort while reducing costs and the building's carbon footprint.

Market analysis indicates that companies with sustainability initiatives tend to profit more and perform better than competitors without these programs.<sup>1</sup> Sustainability programs increasingly are recognized as a source of innovation and a way to improve the appeal of a company or brand.<sup>2</sup> One path towards increased sustainability includes the lighting environment. The design and installation of a highly efficient and long-life lighting system provides a high-profile, visual indicator of a company's commitment to energy efficiency.

Such a commitment can reap positive benefits with employees and clientele, as well. For example, consumers have become increasingly concerned about their impact on the environment and aware of how their shopping habits affect the planet. Retailers have responded by increasing the sustainability of their products and business practices. Improving efficiency and reducing waste not only lowers overhead costs for building owners but also provides an opportunity for business growth.<sup>3</sup>



## LAYERS OF LIGHT

Adding task and accent lighting to ambient lighting, also referred to as general lighting, allows the ambient lighting loads to be reduced without compromising safety or visual comfort. In fact, this layered approach to lighting improves visual comfort by reducing contrast. Lighting designs that include task and accent lighting are thought to be more attractive by some, as they provide variety and visual interest.

## GENERAL AND PERSONAL LIGHTING CONTROLS

General lighting controls address an entire space or area. These controls are typically programmed to provide general purpose areas with energy-efficient control strategies. For example, corridors equipped with occupancy sensors that enable bi-level lighting are one form of general lighting control.

Personal lighting controls address a sub-area and are typically associated with an individual's workstation or task area. For example, lighting installed at a desk to provide illumination only on the desk plane is controlled separately from the overhead lighting in place for the entire office. The personal and general lighting described above are examples of layers of light in a lighting design.

<sup>1</sup> 2013 Retail Sustainability Report: Fueling Continuous Development, 2013, Retail Industry Leaders Association (RILA).

<sup>2</sup> The Innovation Bottom Line: Findings from the 2012 Sustainability & Innovation Global Executive Study and Research report, February 2013, MIT Sloan Management Review.

<sup>3</sup> 2013 Retail Sustainability Report: Fueling Continuous Development, 2013, Retail Industry Leaders Association (RILA).

## HEALTH AND WELLNESS

There is growing evidence indicating that the intensity and spectrum of light sources found in homes and workplaces have a significant impact on health and well-being. The spectral impact relates predominantly to hormonal imbalances on a diurnal basis that affect our natural cycles, or “circadian rhythms”. Circadian-friendly design creates environments that resemble the intensity and spectral variations of light over the course of a day. During the daytime, access to daylight throughout the home or workplace also supports circadian wellness. Avoiding blue spectrum content at night is recommended to maintain appropriate melatonin production throughout the evening.

### THE WELL STANDARD v2.wellcertified.com

*The WELL lighting standard aims to create lighting environments that are optimal for visual, mental and biological health.*



## ABOUT THIS GUIDE

This is one of seven guides designed to help builders, designers, contractors and others involved in the compliance process become more familiar with California’s Energy Code. It is designed to serve as a resource for industry professionals involved in the design, construction or retrofit of California’s buildings. The guides include compliance requirements and recommendations for implementing the Energy Code in New Construction, Addition or Alteration projects.

All seven guides can be found on the Energy Code Ace website ([EnergyCodeAce.com](http://EnergyCodeAce.com)).

Application Guide	What's Covered
<b>Nonresidential Envelope and Solar-Ready Areas</b>	<ul style="list-style-type: none"> <li>Climate-specific design</li> <li>Insulation</li> <li>Cool Roofs</li> <li>Solar zone</li> <li>Fenestration</li> <li>Compliance documentation details</li> </ul>
<b>Nonresidential Lighting and Electrical Power Distribution</b>	<ul style="list-style-type: none"> <li>Lighting design strategies</li> <li>Controls</li> <li>Electrical power distribution</li> </ul>
<b>Nonresidential HVAC and Plumbing</b>	<ul style="list-style-type: none"> <li>Mechanical systems and plumbing systems</li> <li>Commissioning, HERS process and acceptance testing</li> </ul>
<b>Process Equipment and Systems</b>	<ul style="list-style-type: none"> <li>Process loads</li> <li>Applicable products and systems such as kitchen hoods, parking garage ventilation, laboratory fume hoods, elevators, escalators and compressors</li> </ul>
<b>Residential Envelope and Solar</b>	<ul style="list-style-type: none"> <li>Single family homes</li> <li>Duplexes</li> <li>Climate-specific design</li> <li>Insulation</li> <li>Cool Roofs</li> <li>Solar PV (Photovoltaics)</li> <li>Fenestration</li> <li>Compliance documentation details</li> <li>Battery Storage</li> </ul>
<b>Residential Lighting</b>	<ul style="list-style-type: none"> <li>Lighting design strategies</li> <li>Compliant products</li> <li>Controls</li> </ul>
<b>Residential HVAC and Plumbing</b>	<ul style="list-style-type: none"> <li>HVAC terminology</li> <li>Heating and cooling system types</li> <li>Hot water system types</li> </ul>

**2019 ENERGY STANDARDS**

California's Energy Code has saved Californians billions in reduced electricity bills since 1977.

To view the Energy Code online, visit [www.energy.ca.gov/programs-and-topics/programs/building-energy-efficiency-standards/2019-building-energy-efficiency](http://www.energy.ca.gov/programs-and-topics/programs/building-energy-efficiency-standards/2019-building-energy-efficiency).

**ENERGY CODE ACE**

[EnergyCodeAce.com](http://EnergyCodeAce.com)

The Energy Code Ace website is provided by the California Statewide Codes & Standards Program, which offers free training, tools and resources for those who need to understand and meet the requirements of the Energy Code and the Appliance Efficiency Regulations.

**COMPLIANCE PROCESS OVERVIEW**

Chapter 1 includes an overview of the compliance process that outlines the responsibilities, requirements and documentation involved in each phase of a project, from design to final inspection.

**CONCEPTS AND PRINCIPLES**

Chapter 2 discusses lighting concepts and principles, including color quality metrics, correlated color temperature, light output and lamp life. These concepts are vital for making informed decisions about lamps, luminaires and controls.

**TECHNOLOGY, SYSTEMS AND COMPLIANCE STRATEGIES**

Chapter 3 examines how to create an effective lighting system by pairing the correct light source technology with the appropriate fixture and lighting controls. This guide focuses on light sources, control devices and control strategies.

This section of the guide also describes luminaire classification under the Energy Code, control strategies and control systems relevant to nonresidential spaces.

**COMPLIANCE REQUIREMENTS**

Chapter 4 explains Mandatory requirements in the Energy Code related to electric lighting, daylighting and lighting controls. This chapter also examines the Prescriptive requirements of the Energy Code, including the approved methods to calculate allowed lighting power for indoor and outdoor applications.

**REQUIREMENTS AND RECOMMENDATIONS:  
PRESCRIPTIVE APPROACH IN PRACTICE**

Chapter 5 includes requirements and recommendations for meeting the Energy Code in specific nonresidential space types. This portion of the guide focuses on how to apply the Prescriptive Approach to retail, office and educational spaces. Example exercises are included, detailing the steps for the Prescriptive Approach, as well as how to complete relevant forms.

---

**NOTE:** This guide is not intended to be used in lieu of California's Energy Code, and it is not a substitute for the Energy Code itself. Please visit [www.energy.ca.gov/programs-and-topics/programs/building-energy-efficiency-standards/2019-building-energy-efficiency](http://www.energy.ca.gov/programs-and-topics/programs/building-energy-efficiency-standards/2019-building-energy-efficiency) to obtain the official 2019 Energy Code, Reference Appendices and Nonresidential Compliance Manual.



## NEW IN 2019: AN OVERVIEW OF UPDATES

Those familiar with the 2016 Energy Code will find several changes to the lighting requirements in the 2019 Energy Code. Below is an overview of the most significant updates.



### LIGHTING POWER ALLOWANCES

On average, indoor lighting power allowances have been reduced by 37% for the Complete Building Method and 29% for the Area Category and Tailored Method. Outdoor lighting power allowances have been reduced by an average of 23%. These reductions are based on the assumption that all New Construction, Alterations and Additions will be installing LED lighting technologies by January 1, 2020. The Energy Commission estimates this to be the single largest savings in the 2019 Energy Code for nonresidential occupancies.



### POWER ADJUSTMENT FACTORS

New power adjustment factors (PAFs) have been added to encourage the use of clerestory fenestration, horizontal slats and light shelves. Existing PAFs from the 2016 Energy Code also remain as options, for a total of seven PAFs.



### ADDITIONS, ALTERATIONS AND REPAIRS

The Additions, Alterations and Repairs section has been simplified. Now, the trigger for all Alterations is 10% of the luminaires serving an enclosed space. Similar to 2016, there are three paths to compliance, but now, all share a universal set of exemptions and more clear-cut requirements.



#### HEALTHCARE FACILITIES

*The 2019 Energy Code now includes requirements for Group I2 healthcare facilities, although there are many exceptions for this building type.*

*It is important to note that healthcare facilities are exempt from many lighting requirements, including multi-level lighting controls, shut-OFF controls and demand responsive controls.*

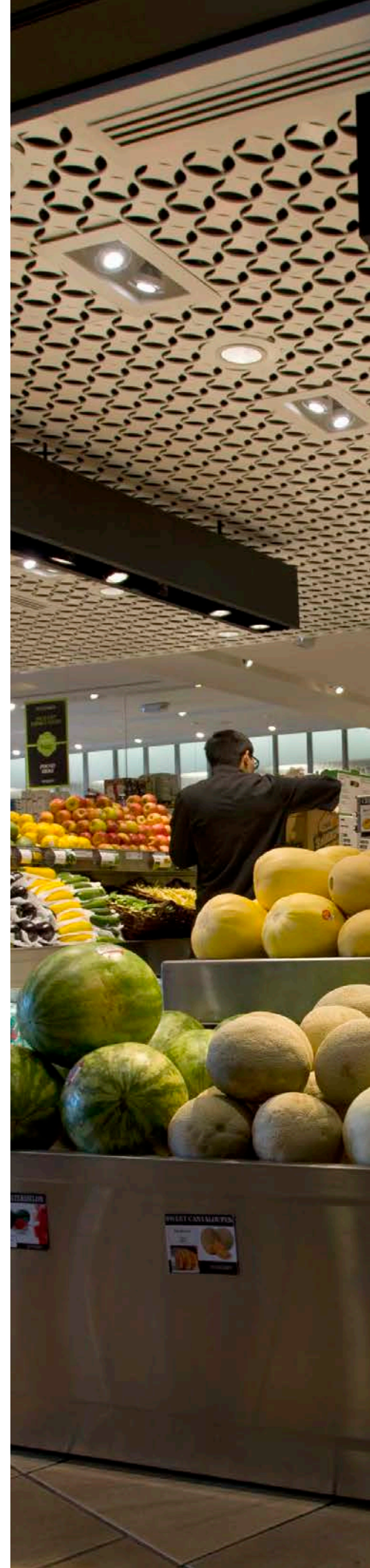



## THE COMPLIANCE PROCESS

---

The Energy Code requires the following process for all New Construction, Additions and Alterations of existing buildings where a permit is issued.

### **STEP 1: COMPLY WITH ALL MANDATORY MEASURES**

All nonresidential buildings must be designed and built to comply with the Mandatory Measures of the Energy Code using devices that adhere to the Appliance Efficiency Regulations. Mandatory Measures are the basic set of requirements that apply to all buildings. For example, lighting controls are Mandatory Measures.

### **STEP 2: COMPLY WITH APPLICABLE PRESCRIPTIVE OR PERFORMANCE MEASURES**

In addition to meeting the Mandatory requirements for your project, commercial buildings and common areas of hotel, motel and multifamily buildings must adhere to the applicable Prescriptive or Performance Measures.

**Prescriptive Approach:** The Prescriptive Approach allows builders to comply by using methods known to be efficient. This approach does not require software — rather, it is completed in a checklist format using the Certificates of Compliance.

**Performance Approach:** The Performance Approach allows builders freedom of design so long as the building achieves the same overall efficiency as an equivalent building using the Prescriptive option. This approach requires using software approved by the Energy Commission and is best suited for use by experienced professionals familiar with the Energy Code. This method allows for energy trade-offs between building systems. For example, under the Performance Approach, use of highly efficient lighting can allow for a larger portion of the energy budget to be allocated to heating and cooling loads.

### **STEP 3: VERIFY COMPLIANCE**

After choosing a compliance method, calculate the proposed energy use of the building or spaces within the building. This value should not exceed the allowed energy budgets specified in the Energy Code. If the design does not comply, it will have to be revised.

### **STEP 4: PREPARE AND SUBMIT PLANS**

Once the Energy Code requirements have been met, the design team prepares the building plans and Certificates of Compliance. Plans and compliance forms are submitted to the appropriate enforcement agency, together with a building permit application.



#### **STEP 5: PASS PLAN REVIEW AND RECEIVE PERMIT**

A building department plans examiner must check that the building design satisfies the Energy Code requirements and that the submitted documentation contains all information to be verified during field inspection. A building permit is issued after plans are reviewed for compliance and approved.

#### **STEP 6: COMPLETE CONSTRUCTION**

The installation team must follow the approved plans and specifications during construction. Certificates of Installation must be completed and signed by licensed individuals to certify that the lighting installed for the project corresponds with the lighting proposed on the Certificates of Compliance.

#### **STEP 7: COMMISSION BUILDING SYSTEMS**

After construction is complete, the contractor or the design team must properly commission, or bring into working condition, the building and its systems. They also must advise the building owners and operators of their responsibilities regarding compliance with the Energy Code. They must provide information and training to the building owner on how to maintain and operate the building systems.

#### **STEP 8: PASS ACCEPTANCE TESTING**

The Energy Code requires that Certified Lighting Controls Acceptance Test Technicians (CLCATT) review and test newly installed building systems to ensure the controls and connected loads operate as required by the Energy Code.

#### **STEP 9: PASS FINAL INSPECTION**

The building department field inspector(s) must verify that the building construction follows the plans and specifications that were approved when the building permit was issued. Once final inspection is complete, the Certificate of Occupancy is issued.

#### **STEP 10: PROVIDE DOCUMENTATION TO BUILDING OWNERS**

Upon occupancy, the building owner must receive copies of the energy compliance documents from the installation team, including Certificates of Acceptance, along with instructions for operation and maintenance.

## COMPLIANCE DOCUMENTS

### DYNAMIC FORM WALKTHROUGH

The NRCC-LTI-E form is now dynamic. The data you put in will affect which form sections are required, reducing the individual forms that need to be downloaded and streamlining the process for lighting compliance.

For a detailed look at how to use the form, Energy Code Ace has created a video walkthrough for users. You can review the steps for completion on YouTube at <https://youtu.be/qv6S3xQOCEU>.



The compliance process includes the completion of an extensive set of forms, which must be submitted for review by a plans examiner within the authority having jurisdiction. Not all forms are required for all projects.

Instructions for completing these forms are provided in Section 5.11 of the Energy Commission's **Nonresidential Compliance Manual**.

- CC:** Certificate of Compliance      **O:** Outdoor      **E:** Verified by
- CA:** Certificate of Acceptance      **I:** Indoor      Enforcement Authority
- CI:** Certificate of Installation      **S:** Signs      **A:** Completed by
- CV:** Certificate of Verification           Acceptance Tester

**NR CA – LTI – 02 – A**

- NR:** Nonresidential
  - CF:** Residential
  - LT:** Lighting
  - CXR:** Commissioning Review
  - ELC:** Electrical
  - ENV:** Envelope
  - MCH:** Mechanical
  - PLB:** Plumbing
  - PRC:** Process
- Number in Sequence

### CERTIFICATES OF COMPLIANCE

Certificates of Compliance and building plans are submitted at the same time that a building permit application is submitted to the enforcement agency. (See Step 4 in the compliance overview.) Some Certificates of Compliance are mandatory for every project, while others are required only if the system design includes specific components or strategies.

- NRCC-LTI-E**      Indoor Lighting
- NRCC-LTO-E**      Outdoor Lighting
- NRCC-LTS-E**      Sign Lighting
- NRCC-ELC-E**      Electrical Power Distribution

Because lighting power trade-offs are not allowed between conditioned and unconditioned spaces, conditioned and unconditioned space types must show compliance separately.

STATE OF CALIFORNIA  
**Indoor Lighting**  
NRCC-LTI-E (Created 01/20)

CALIFORNIA ENERGY COMMISSION  
NRCC-LTI-E

**CERTIFICATE OF COMPLIANCE**  
This document is used to demonstrate compliance with requirements in §110.9, §110.12(c), §130.0, §130.1, §140.6, and §141.0(b)2 for indoor lighting scopes using the prescriptive path.

Project Name: \_\_\_\_\_ Report Page: \_\_\_\_\_ Page 1 of 5  
Project Address: \_\_\_\_\_ Date Prepared: \_\_\_\_\_

**A. GENERAL INFORMATION**

01 Project Location (city)	04 Total Conditioned Floor Area (ft <sup>2</sup> )
02 Climate Zone	05 Total Unconditioned Floor Area (ft <sup>2</sup> )
03 Occupancy Types Within Project (select all that apply):	06 # of Stories (Habitable Above Grade)
<input type="checkbox"/> Office <input type="checkbox"/> Retail <input type="checkbox"/> Warehouse <input type="checkbox"/> Hotel/Motel <input type="checkbox"/> School <input type="checkbox"/> Support Areas	
<input type="checkbox"/> Parking Garage <input type="checkbox"/> High-Rise Residential <input type="checkbox"/> Relocatable <input type="checkbox"/> Healthcare <input type="checkbox"/> Other (write in): _____	

**B. PROJECT SCOPE**

Table Instructions: Include any lighting systems that are within the scope of the permit application and are demonstrating compliance using the prescriptive path outlined in §140.6 or §141.0(b)2 for alterations. WARNING: Changing the Calculation Method in this table will result in the deletion of data previously input. If you need to change the calculation method, please open a new form or use "Save As".

Scope of Work	Conditioned Spaces		Unconditioned Spaces	
	01	02	03	04
My Project Consists of (check all that apply):	Calculation Method	Area (ft <sup>2</sup> )	Calculation Method	Area (ft <sup>2</sup> )
<input type="checkbox"/> New Lighting System				
<input type="checkbox"/> Altered Lighting System				
	Add Parking Garage-Complete Bldg Method		Remove Parking Garage	
	Add Altered Lighting System		Remove Last Altered System	
<b>Total Area of Work (ft<sup>2</sup>)</b>				

**C. COMPLIANCE RESULTS**

Table Instructions: If any cell on this table says "DOES NOT COMPLY" or "COMPLIES with Exceptional Conditions" refer to Table D. for guidance.

### NONRESIDENTIAL LIGHTING COMPLIANCE FORMS

As part of the Energy Code compliance process, the design team must prepare and submit documents to verify compliance. (See Step 4.)

The Energy Commission has made these compliance documents, or examples of these documents, available at [energycodeace.com/NonresidentialForms/2019](http://energycodeace.com/NonresidentialForms/2019).

## CERTIFICATES OF INSTALLATION

Certificates of Installation, signed by licensed professionals, certify that the lighting installed for the project corresponds with the lighting proposed on the Certificates of Compliance.

<b>NRCI-ELC-01-E</b>	Electrical Power Distribution
<b>NRCI-LTI-01-E</b>	Indoor Lighting
<b>NRCI-LTI-02-E</b>	Energy Management Control System or Lighting Control System
<b>NRCI-LTI-04-E</b>	Two Interlocked Lighting Systems
<b>NRCI-LTI-05-E</b>	Power Adjustment Factors
<b>NRCI-LTI-06-E</b>	Videoconference Studio Lighting
<b>NRCI-LTO-01-E</b>	Outdoor Lighting
<b>NRCI-LTO-02-E</b>	Energy Management Control System or Lighting Control System
<b>NRCI-LTS-01-E</b>	Sign Lighting

**NRCI-LTI-01-E** is required for all indoor lighting projects. **NRCI-LTO-01-E** is required for all outdoor lighting. The other forms may be required based on the specific lighting systems installed.

## CERTIFICATES OF ACCEPTANCE

A CLCATT, trained and certified through a state-approved program, must complete Certificates of Acceptance when required. The forms also are signed by the responsible person and the document author. These signatories may be different than the CLCATT. Information in these forms certifies that the lighting controls were tested and operate in compliance with the Energy Code:

<b>NRCA-LTI-02-A</b>	Shut-off Lighting Controls
<b>NRCA-LTI-03-A</b>	Automatic Daylighting Controls
<b>NRCA-LTI-04-A</b>	Demand Responsive Lighting Controls
<b>NRCA-LTI-05-A</b>	Institutional Tuning PAF
<b>NRCA-LTO-02-A</b>	Outdoor Lighting Controls
<b>NRCA-ENV-03-F</b>	Daylighting Design PAFs

### LIGHTING APPLIANCE EFFICIENCY REGULATION UPDATES

The Energy Commission adopted new standards updating the Appliance Efficiency Regulations (Title 20), for lighting appliances. Updates will roll out in two tiers with Tier 1 effective January 1, 2018 and Tier 2 effective July 1, 2019. Notably, this update adds standards for small-diameter directional lamps and updated definitions.



## FINDING COMPLIANT PRODUCTS

Certain lighting products must be certified to the Energy Commission as meeting California's Appliance Efficiency Regulations (Title 20, Section 1601–1608 of the California Code of Regulations). Others are regulated only under the Energy Code.

### PRODUCTS REGULATED UNDER THE APPLIANCE EFFICIENCY REGULATIONS

The following lighting products are regulated under the Appliance Efficiency Regulations. The Energy Code references these requirements.

- Fluorescent lamp ballasts
- Ceiling fan light kits
- Lamps
- Emergency lighting
- Torchieres and metal halide luminaires
- Power supplies

### PRODUCTS REGULATED UNDER THE ENERGY CODE

The following lighting control devices are regulated under **Section 110.9** of the Energy Code only:

- Lighting control devices
  - Time-switch lighting controls: automatic time-switch controls, astronomical time-switch controls, multi-level astronomical time-switch controls, outdoor astronomical time-switch controls
  - Daylighting controls: automatic daylight controls, photo controls
  - Dimmers
  - Occupant sensing controls: occupancy sensors, motion sensors, vacancy sensors, partial-ON sensors, partial-OFF sensors
  - Part-night outdoor lighting controls
- Track lighting integral current limiter
- Supplementary overcurrent protection panels for use with line-voltage track lighting
- Field-assembled lighting control systems

### APPLIANCE EFFICIENCY DATABASE [www.energy.ca.gov/rules-and-regulations/appliance-efficiency-regulations-title-20/appliance-regulations-certification](http://www.energy.ca.gov/rules-and-regulations/appliance-efficiency-regulations-title-20/appliance-regulations-certification)

This online database of products certified to the Energy Commission has a Quick Search function allowing users to search by product type, brand or model name.



### MODERNIZED APPLIANCE EFFICIENCY DATABASE (MAEDBS)

The Energy Commission's Modernized Appliance Efficiency Database (MAEDBS) lists a variety of products certified as meeting the Appliance Efficiency Regulations or the Energy Code, including lighting control devices, lamps, ballasts and ceiling fan light kits.

Lighting specifiers wishing to work with a product not yet listed in the Appliance Efficiency Database can encourage the manufacturer or a pre-approved third-party certifier to submit appliance certification data to the Energy Commission.



### ENERGY STAR®

While many **ENERGY STAR®** products meet California’s efficiency requirements, not all ENERGY STAR® labeled products comply with the Energy Code. In some cases, California’s compliance requirements are more stringent. Consult MAEDBS to see if an ENERGY STAR® product complies with California requirements.

### DESIGNLIGHTS CONSORTIUM®

The **DesignLights Consortium (DLC)** maintains a Qualified Products List that provides information on available products for the commercial sector that passed a review of test results as verification of performance. Members of the DLC are comprised of regional, state, utility and energy efficiency programs throughout the United States and Canada. Products on the list often are eligible for incentives through participating programs.

### FTC LABEL

The **FTC label** summarizes lighting characteristics for products from manufacturers who commit to testing products and reporting performance results according to industry standards.

#### COMPLIANT LED LABELING

*Below are samples of compliant lighting labeling from the various organizations that review products.*



Lighting Facts Per Bulb	
<b>Brightness</b>	<b>800 lumens</b>
<b>Estimated Yearly Energy Cost</b>	<b>\$1.18</b>
Based on 3 hrs/day, 11¢/kWh Cost depends on rates and use	
<b>Life</b>	
Based on 3 hrs/day	<b>22.8 years</b>
<b>Light Appearance</b>	
Warm <span style="display: inline-block; width: 100px; border-bottom: 1px solid black; position: relative; top: -5px;"> <span style="position: absolute; left: 0; top: -5px;">▲</span> <span style="position: absolute; right: 0; top: -5px;">▼</span> </span> Cool	
	2700 K
<b>Energy Used</b>	<b>9.8 watts</b>





# CONCEPTS AND PRINCIPLES

## LAYERS OF LIGHT

Adding task and accent lighting to spaces lit with general, ambient lighting allows ambient lighting loads to be reduced without compromising safety or visual comfort. In fact, this layered approach to lighting improves visual comfort by reducing contrast. Lighting designs that include task and accent lighting are also considered more attractive by some, as they provide variety and visual interest.

### AMBIENT LIGHTING

Ambient lighting should provide a comfortable level of brightness without causing glare. Most rooms benefit from having an ambient light source in the form of a ceiling-mounted luminaire, recessed light, wall-mounted luminaire or a suspended pendant.

### TASK LIGHTING

Task lighting supplements ambient lighting and maximizes efficiency by placing light closer to the work area. Users can switch it on when needed. Compact desktop task lighting, for example, provides extra light for document preparation and review. Undercabinet lighting in break rooms and commercial kitchens makes cooking and food preparation safer and easier.

Task lighting should be bright enough to prevent eye strain without causing glare. Multiple light sources can cast shadows that make tasks more difficult. High-quality task lighting makes visual tasks easier. It also allows for lower ambient light levels, reducing energy use.

### DAYLIGHTING

Where daylight is available, electric light levels often can be lowered. In addition to reducing energy use, daylight is full spectrum that offers excellent color rendering. Controls and window or skylight treatments can be used to prevent glare and unwanted solar heat gain from daylight.

### ACCENT OR DISPLAY LIGHTING

Track lighting, cove lighting and wall-mounted luminaires are common choices for accent lighting. These luminaires can highlight architectural features, spotlight artwork or illuminate interior design elements.

Color-tunable LED products are becoming more prevalent and more affordable, offering new options for accent lighting. For instance, with the press of a button, retailers can wash their walls with colored light to temporarily accent key product displays.

**DAYLIGHT HARVESTING FOR COMMERCIAL BUILDINGS GUIDE**  
*Maximizing daylight harvesting potential in building spaces is an efficient way to save energy. CLTC has published the Daylight Harvesting for Commercial Buildings Guide to help make design decisions that meet or exceed the Energy Code's performance goals.*

To learn more about daylighting, refer to the **Daylight Harvesting for Commercial Buildings Guide**.

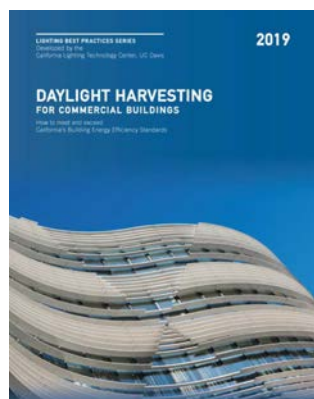

## LIGHT OUTPUT, EFFICACY AND LIFE

### VISION NEEDS CHANGE WITH AGE

As we age, our eyes require more light to see clearly. The Illuminating Engineering Society of North America (IES) sets lowest average minimum maintained recommendations for light level (fc or lux) requirements based on the needs of occupants under 25 years old. These illumination recommendations are doubled for those ages 26–65 and quadrupled for those older than age 65.



Many estimate the light output of lamps and luminaires based on the amount of power they draw, but it is lumens (lm), not watts (W), that describe the amount of light output. Efficient light sources produce more light for less power.

### LIGHT OUTPUT

The amount of visible light emitted by a light source is measured in lumens (lm). The more lumens, the more light emitted, but other factors also affect visibility and perception of brightness, such as contrast ratios and color characteristics. In addition, the type of fixture or housing can greatly affect the amount of lighting reaching the intended target or task plane.

### RECOMMENDATIONS

- Compare the light output, not the power rating, of existing and replacement light sources to ensure adequate lighting is maintained.
- Consider other factors, such as contrast, distribution and color rendering; these also affect nighttime vision and perceived brightness.
- Install lighting controls, such as dimmers or motion sensors, to maximize energy savings while automatically tailoring light levels to occupants' needs.
- To avoid energy waste and excessive illumination, factor task lighting and ambient lighting into the overall lighting design for a space.

### INCENTIVE PROGRAMS

When purchasing an energy-efficient product, such as an LED light fixture, check with your local utility to understand which incentives or rebates you are qualified to utilize on your project.



### LUMINOUS EFFICACY

In lighting, the term efficacy refers to the ratio of light output (lm) produced by a light source to the power of that source.

$$\text{Efficacy} = \text{Lumens} / \text{Watts}$$

Each light source technology has a typical efficacy level. For example, a 75W A19 incandescent lamp, a 16W A19 compact fluorescent lamp (CFL) lamp and a 15W A19 LED lamp use different amounts of power to produce the same amount of light (approximately 1,100 lumens). Each type of lamp has a different rated efficacy, with the LED example being the most efficacious (producing the most lumens per watt).

When assessing the overall value of a light source, efficacy and longevity should be considered along with initial product cost. Lifetime energy and maintenance costs often can eliminate any cost savings achieved by choosing a lower initial cost, less efficient product.

### WHAT IS A LAMP?



In the lighting industry, the term 'lamp' refers to an electrical appliance that produces optical radiation for the purpose of visual illumination. Lamps are designed with a base to provide an electrical connection between the light source and power source and are designed to be installed into a light fixture. The term 'lamp' is synonymous with 'bulb'.

Common examples of lamps include the A19 (left) and MR16 (right) form factors.



PHOTO:  
CLTC, UC DAVIS

### Light Source Comparison Chart

			
LAMP TYPE	60 watt Incandescent	13 watt CFL	9.5 watt LED
Light Output (lm)	850	800	800
Watts (W)	60	13	9.5
Efficacy (lm/W)	14	62	84
Life Span (hr)	1,000	8,000	25,000
Price per Lamp	\$0.50	\$5.00	\$10.00

Source: Greater Cincinnati Energy Alliance, March 24, 2015.  
<https://greatercea.org/lightbulb-efficiency-comparison-chart/>

## LIFE

Electric light sources have the potential to fail due to several factors, including faulty electrical components, corrosion inside the lamp or lumen depreciation (the gradual decrease in light output that occurs over time).

Incandescent lamps typically last 1,000–2,000 hours and lose about 10–15% of their initial light output before burning out completely. CFL lamps last about 12,000 hours and lose about 10–15% of their light output before burning out completely. Linear fluorescent lamps typically last 25,000–40,000 hours and lose 5–10% of their original light output before they fail.

LEDs do not burn out or fail suddenly in the same way as incandescent or fluorescent light sources. Instead, their light output decreases gradually over time. Many LED A19 replacement lamps are rated to last 25,000 hours or more before they lose 30% of their initial light output. In addition, testing indicates the LEDs in these products may maintain useful light output longer than these estimates. A few best practices can help maximize the life of LED lighting:

### RECOMMENDATIONS

- Always follow manufacturer installation instructions, including references to base position for replacement lamps (e.g., base-up, base-down or horizontal).
- Pair LED lamps and luminaires with manufacturer-recommended dimmers and other controls.
- Observe manufacturers' recommendations on operating temperature to prevent heat-related performance degradation.

### WARRANTIES

Manufacturers offer competitive warranties for lighting products. ENERGY STAR® requires that luminaires and LED lamps carry a warranty of at least three years.



# COLOR CHARACTERISTICS

## CORRELATED COLOR TEMPERATURE (CCT)

Correlated color temperature (CCT) indicates the warmth or coolness of the light emitted by a light source. CCT (or "light color") is measured on the Kelvin (K) scale. Light sources with a low CCT (2,700–3,000K) emit light that is warm in appearance. Sources with higher CCT values (4,000–6,500K) provide light with a cooler color appearance.

Selecting light sources with consistent CCTs helps maintain uniformity in the appearance of a lighting system that contains multiple luminaires. Check the Lighting Facts label for information on CCT, light output, power and life.

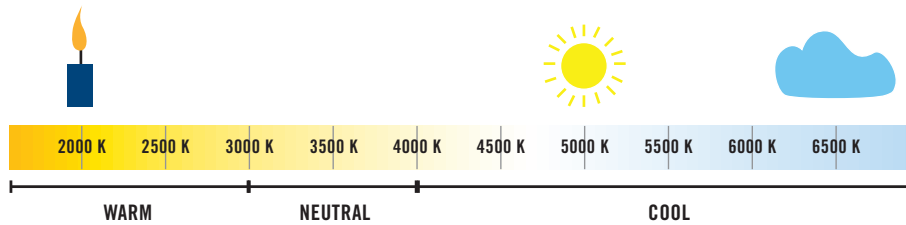

### LIGHTING FACTS LABEL

The basic lighting facts label can be found on the packaging for a light source and provides valuable information on the light source's color characteristics, including the Correlated Color Temperature.

Lighting Facts Per Bulb	
<b>Brightness</b>	<b>800 lumens</b>
<b>Estimated Yearly Energy Cost</b>	<b>\$1.18</b>
Based on 3 hrs/day, 11¢/kWh Cost depends on rates and use	
<b>Life</b>	<b>22.8 years</b>
Based on 3 hrs/day	
<b>Light Appearance</b>	
Warm ————— Cool	
2700 K	
<b>Energy Used</b>	<b>9.8 watts</b>

### COLOR LIGHTING FACTS LABEL

The full-color Lighting Facts label issued by the Department of Energy includes CRI, but the black-and-white Federal Trade Commission label does not.

lighting facts <sup>CM</sup>	
A Program of the U.S. DOE	
<b>Light Output (Lumens)</b>	<b>315</b>
<b>Watts</b>	<b>9.3</b>
<b>Lumens per Watt (Efficacy)</b>	<b>33</b>
<b>Color Accuracy</b> Color Rendering Index (CRI)	<b>83</b>
<b>Light Color</b> Correlated Color Temperature (CCT)	<b>2994 (Warm White)</b>
<small>All results are according to IESNA LM-79-2008: Approved Method for the Electrical and Photometric Testing of Solid-State Lighting. The U.S. Department of Energy (DOE) verifies product test data and results. Products qualified under the DOE ENERGY STAR program have the ENERGY STAR mark on this label. Visit <a href="http://www.lightingfacts.com">www.lightingfacts.com</a> for the Label Reference Guide. Registration Number: W545-ANJ2719 Model Number: FJ-SCD-K-XX Type: Other</small>	



## COLOR RENDERING INDEX (CRI)

The color rendering index (CRI) is the current industry standard for measuring how accurately a light source renders the colors of the objects it illuminates. The maximum CRI value is 100.

Specifying lamps and luminaires with similar color rendering properties helps ensure that wall color, carpeting and other materials have a consistent appearance, especially in adjoining spaces. Most manufacturers can supply information on CRI if it is not immediately available on product packaging or literature. For LED light sources, request the product's LM-79 report from the manufacturer.

### INDIVIDUAL COLORS (R1–R15)

In the current CRI metric, 15 reference colors are used to compare color rendition. The average CRI ( $R_a$ ) metric measures a light source against the first eight reference colors (R1–R8). The ninth reference color, R9, is used to measure how a light source’s spectral output renders vibrant reds. This measurement is especially critical to consider when illuminating items with saturated red elements, including clothing, jewelry, leather goods and wood finishes. Cosmetics and customers’ skin tones also appear more vibrant when illuminated by sources with an R9 measurement greater than 50. While the R9 value is not always printed on the lighting facts label, many manufacturers can provide spectrum measurements, including R9 values. For LED light sources, request the product’s LM-79 report from the manufacturer for this information.



### IES TM-30-18

In 2018, a new method for evaluating light source color rendition, known as TM-30-18, was developed by the Illuminating Engineering Society (IES). TM-30-18 takes an objective and statistical approach to color rendition, quantifying the fidelity (closeness to a reference) and gamut (increase or decrease in chroma) of a light source.

#### COMPARING COLOR QUALITY

The LED MR16 lamps used for these photos both have a CCT of 3,000K and were produced by the same manufacturer. The image on the left is illuminated with an 80 CRI light source, while the image on the right is illuminated with a 95 CRI light source.

#### INDIVIDUAL COLOR PALETTES



#### TM-30-18

[www.ies.org/product/ies-method-for-evaluating-light-source-color-rendition/](http://www.ies.org/product/ies-method-for-evaluating-light-source-color-rendition/)

The TM-30-18 metric is calculated for a light source by using the spectral power distribution data acquired during an LM-79 test and an Excel-based calculator tool available from IES.







## CHAPTER 3

# TECHNOLOGY, SYSTEMS AND COMPLIANCE STRATEGIES

## CHOOSING THE RIGHT LIGHT

An effective lighting system combines the right source technology with the right fixture and the appropriate lighting controls for the desired function and effect. Selecting the right type of light source and lighting controls for nonresidential lighting needs means comparing a variety of factors, including:

- Light output
- Efficacy
- Distribution
- Color rendering
- Controls compatibility
- Correlated color temperature
- Spectral content
- Product life
- Manufacturer warranties
- Long-term energy and cost savings

In many cases, a higher up-front investment in a more efficient, functional lighting system yields a better return in the long term as compared to low-cost alternatives. This is especially true in retail applications where lighting quality can influence sales.

The following technology overview briefly describes the benefits and limitations of commercially-available lighting technology. It also offers guidance for selecting products that comply with the Energy Code and the Appliance Efficiency Regulations.

### LIGHTING DESIGN TOOLS

[lightinganalysts.com](http://lightinganalysts.com)

Looking for tools to help you efficiently design your lighting system? Many manufacturers' websites provide modeling tools. For more in-depth lighting calculations, there are simulation tools available for purchase, such as AGi32 from Lighting Analysts.



## LIGHT SOURCES



PHOTO: UC DAVIS

A single luminaire often can accommodate different light sources. For example, screw-based fixtures are designed to accept incandescent, CFL or LED sources. Selecting the best source type for a particular application means considering several factors, including light quality, intensity, efficiency and longevity.

### LED

LEDs are solid-state light sources capable of emitting colored light, white light or spectrally-tunable light. The color quality of white light LEDs depends on the design and manufacturing of the LED chip.

- Installing long-life LED luminaires can reduce maintenance costs and reduce time spent changing failed lamps. LED lighting is excellent for nearly all applications, indoors or outdoors.
- LEDs are dimmable and unaffected by frequent switching. In addition, their compatibility with cold temperatures make them an excellent choice for pairing with occupancy-based controls, such as those used in adaptive freezer case lighting and cold climate outdoor applications.
- Spectrally-tunable LEDs introduce a new element of flexibility for lighting. This technology has benefits in healthcare and hospitality applications, where spectral properties of all light sources can impact wake/sleep cycles, or circadian rhythms, if the exposure time is significant.



PHOTO: CREE

LED alternatives to fluorescent lighting products fall into three main categories: linear (or tubular) lamps, retrofit kits and dedicated luminaires. These LED replacement options have different labor installation times, costs and safety precautions.

### LINEAR LED LAMPS

Linear fluorescent lamps comprise 80% of the lamp inventory in the commercial sector, or about 1.7 billion lamps, according to a U.S. Department of Energy report.

Replacing existing linear fluorescent lamps with similarly shaped linear LED lamps requires minimal new hardware, but this strategy also presents challenges that should be understood before purchase or installation.

Based on the particular LED replacement lamp product being considered, this approach typically requires changing the electrical wiring, replacing the ballast with an external driver or altering the existing lamp holders (or “tombstones”) to accommodate the new lamp.

LED lamps that replace the fluorescent lamps only, and do not require any lighting wiring alterations, can be considered a Repair and do not trigger the Energy Code compliance process. The Energy Code does not regulate linear LED lamps installed as replacements for linear fluorescent lamps in existing luminaires. A project that replaces both fluorescent lamps and ballasts with LED lamps and drivers is a regulated Alteration. This applies to all similar retrofits regardless of source type (e.g., replacing the fluorescent lamps with an LED UL Type A lamp and new ballast, replacing the fluorescent lamp and ballast with a new fluorescent lamp and ballast).



PHOTO: CLTC, UC DAVIS





**LED RETROFIT OPTIONS FOR LINEAR FLUORESCENT LUMINAIRES**  
[cltc.ucdavis.edu/publication/led-retrofit-options-linear-fluorescent-luminaires](http://cltc.ucdavis.edu/publication/led-retrofit-options-linear-fluorescent-luminaires)

*LED lighting products are receiving a great deal of attention for their potential to replace fluorescent lighting, reduce energy use and improve lighting quality.*

*LED alternatives to fluorescent lighting products fall into three main categories: linear LED replacement lamps, retrofit kits and dedicated luminaires. This guide provides information on each of these three rapidly developing lighting product categories, including safety precautions, photometric performance considerations and labor requirements.*

### LED RETROFIT KITS

An LED retrofit kit provides the required electrical components, optical elements and light sources in a prepackaged kit. This replacement option provides an efficient retrofit solution for the majority of troffers in today's building stock. When updating existing troffers, it is critical to make sure they can accommodate the retrofit kit selected since not all retrofit kits are universally accepted by troffers. Any retrofit option should preserve the safety rating of the existing luminaire.

### DEDICATED LED LUMINAIRES

Dedicated LED luminaires are an excellent alternative to linear fluorescent luminaires. While typically higher in cost than fluorescent products, this option often provides the LED technology in a well-designed package with a straightforward electrical installation.

## LINEAR FLUORESCENT

Linear fluorescent lamps provide uniform levels of illumination for long periods of time, making them appropriate in buildings that require bright, uniform ambient lighting. Linear fluorescent lamps also work well in break rooms, bathrooms, storage spaces and other more utilitarian areas. In addition, these lamps are relatively inexpensive and can provide excellent color rendering.

- Linear fluorescent lamps are available in different wattages and sizes; the 4' 32W T8 is the most common. Low wattage, energy saving alternatives include 28W and 25W lamps. Other products include T5 lamps and lamps in 2' and 8' lengths.
- Not all fluorescent lamps are compatible with dimmable ballasts. Low-wattage lamps often are not recommended for dimming applications.

Also, programmed-start ballasts are best suited for frequently switched applications. Ensure fluorescent products selected are suited for the dimming and the multi-level control requirements included in **Section 130.1** of the Energy Code.

## COMPACT FLUORESCENT LAMPS (CFL)

With CFLs, the linear tube design of traditional fluorescent lights has been curved into a more compact shape, facilitating an incandescent lamp replacement. An electronic ballast, either in the base of the CFL or installed separately, activates the lamp and then regulates the electrical current. Not all CFLs are dimmable and some can have delayed start times, which can be problematic in some applications. These light sources are typically installed in commercial downlights.



PHOTO: CLTC, UC DAVIS



PHOTO: CLTC, UC DAVIS



PHOTO: CLTC, UC DAVIS





PHOTO: CLTC, UC DAVIS

### INCANDESCENT

Incandescent lamps are highly inefficient, but their initial cost is low. These lamps do have excellent color, but they burn out quickly compared to other sources. This can increase maintenance costs over time. In addition, incandescent light sources often provide unwanted heat when used in certain applications. Be selective in choosing applications for incandescent lighting.



PHOTO: KARIN HIGGINS, UC DAVIS

### HALOGEN

Halogen lamps burn hotter and last longer than standard incandescent lamps, producing a brighter, whiter light. Halogen lamps are about 25% more efficacious than standard incandescent lamps. Halogens are a good alternative when incandescent lighting is necessary.

### METAL HALIDE AND HIGH PRESSURE SODIUM

Metal halide (MH) and high pressure sodium (HPS) lighting often is found in outdoor applications. Both are used in some indoor spaces, such as warehouses and other high-bay applications. Metal halide is fairly efficacious and long lived. It can provide CRI of 60 or more. HPS is also very efficacious, but it has poor color properties that produce a yellow light with low CRI. Neither is well-suited for use with occupancy controls or frequent switching. Once extinguished, these technologies take five minutes or more before they can be turned back on.



PHOTO: PHILIPS

Ceramic metal halide (CMH) lamps are a newer variation of MH technology commonly used in spot and track lighting applications. CMH lamps can produce white light with a CRI as high as 96, making them suitable for color-critical applications. Similar to standard MH lamps, CMH can take up to 10 minutes to reach full light output.



PHOTO: CLTC, UC DAVIS

### INDUCTION

Induction lamps operate similarly to fluorescent lamps, but without the electrodes and filaments. Induction sources have long lifetimes and seldom need replacing. These lamps are very efficient and compatible with many types of lighting controls, and its long life (60,000–100,000 hours) means minimal maintenance. Induction lamps often are used in high bay, low bay and outdoor applications.



## CONTROL STRATEGIES

Lighting controls increase the flexibility and functionality of commercial lighting systems. The control requirements of the Energy Code aim to maximize lighting system energy efficiency while also ensuring building occupants are comfortable and safe. There are many control strategies that can be deployed in nonresidential buildings, including occupancy control, scheduling, tuning, daylight harvesting and automated demand response.

Sensors and controls can achieve significant energy savings by automatically adjusting lighting based on time of day, available task needs, daylight, occupancy and electricity supply or cost.

### SCHEDULING

Time switches, commonly used in indoor and outdoor applications, switch lights ON or OFF based on daylight hours and geographical location. Some time clocks and curfew dimming controls automatically can adjust dimmable sources, such as LEDs or CMH lamps, to operate at different light levels according to a schedule. Dimming lights during the least active hours of operation reduces energy waste and light pollution.



◀ Time Clocks (left to right):  
Leviton EZ-MAX Plus B Relay Panel,  
Wattstopper LPB Peanut Lighting  
Control Panels

## TUNING

Tuning, also known as high-end trim or institutional dimming, reduces the level of general lighting in an area. Luminaire layouts typically are designed using a light loss factor, so initial designed light levels often are brighter than necessary to allow for light output degradation over the luminaire's life. Tuning allows the luminaires to be dimmed to the recommended light level initially and later restored to full output when light output has degraded. This strategy saves energy, maintains more consistent light levels over the life of the luminaire and extends lamp life.



◀ *Tuning Controls (left to right):  
Leviton Renoir II dimming control,  
Leviton Sapphire LCD Touch Screen*

### WHAT FEATURES ARE REQUIRED FOR VACANCY SENSORS?

To be in compliance, a vacancy sensor must provide:

- A maximum time out of 20 minutes
- A 15–30 second grace period to automatically turn lighting ON after the sensor has timed out
- No override switch that disables the sensor
- A visible status signal that indicates if the device is operating properly (this signal may have an override if the occupant prefers it OFF)

## VACANCY AND OCCUPANCY SENSORS

Vacancy sensors automatically dim or switch lighting OFF when the sensor's field of view has been vacant for a predetermined, programmed period of time. Lights controlled by vacancy sensors, or manual-ON occupancy sensors, must be turned ON manually. The occupant makes a deliberate decision to add electric lighting. This strategy can result in significant energy reductions when general lighting subsequently remains OFF for the majority of the day.

Occupancy sensors automatically turn lights ON when an occupant is present in the sensor's field of detection. Occupancy sensors can be programmed to turn only a portion of the controlled lights ON or OFF. This strategy is called partial-ON or partial-OFF control.

### WHAT FEATURES ARE REQUIRED FOR OCCUPANCY SENSORS?

To be in compliance, an occupancy sensor must provide:

- A maximum time out of 20 minutes
- A visible status signal that indicates if the device is operating properly (this signal may have an override if the occupant prefers it OFF)
- Allowance for all lights to be manually turned OFF regardless of the status of occupancy



◀ *Occupancy Sensors (top row, left to right):  
Leviton OSSMT Occupancy Sensor, Lighting Control & Design xCella Wireless Occupancy Sensor, Lutron Radio Powr Savr Wireless Occupancy Sensor*

*Vacancy Sensors (bottom row, left to right):  
Leviton Provolt Vacancy Sensor, WattStopper CU-250 Ultrasonic Multi-way Wall Switch Vacancy Sensor*



### DAYLIGHT HARVESTING

Also called photo controls, daylight harvesting devices utilize daylight sensors to adjust lighting loads based on ambient light levels. Daylight controls are required in all spaces that have:

- Skylights, windows or other daylight sources
- At least 120 watts of electric lighting in the combined skylit and primary sidelit daylit zone
- 24 ft<sup>2</sup> of glazing



◀ Daylight Harvesting Controls (left to right): Leviton ODC05-MDW, WattStopper LMS-600, Lutron Radio Powr Savr Wireless Daylight Sensor

### AUTOMATED DEMAND RESPONSE

Utilities initiate demand response events for a variety of reasons. Commercial electricity customers may choose to participate in utility demand response (DR) programs in exchange for financial incentives. These DR events are issued when demand for electricity is expected to exceed generation capacity.

The Energy Code requires all commercial buildings greater than 10,000 ft<sup>2</sup> in size with a lighting power density greater than 0.5 watts per square foot be capable of receiving and automatically responding to DR signals by reducing lighting energy use. Spaces within the building where a health or life safety statute, ordinance or regulation does not permit the lighting to be reduced are not required to have demand responsive controls and do not count toward the 10,000 ft<sup>2</sup> threshold.



◀ Demand Response Controls (left to right): Leviton GreenMax Relay Panel, WattStopper Digital Lighting Management

**WHAT IS THE CLCATT LOOKING FOR?**  
 The Certified Lighting Controls Acceptance Test Technician (CLCATT) ensures that the following indoor lighting control devices and systems are installed and functioning as required by the Energy Code before the building is occupied:

- Automatic daylighting controls
- Automatic time-switch controls
- Occupancy sensor
- Demand responsive controls
- Institutional tuning controls



## LIGHTING CONTROL SYSTEM ARCHITECTURES

Control systems can be as simple as an ON/OFF switch or as complex as a building-level networked control system that integrates daylight harvesting, occupancy sensing, scheduling and demand response. There are four control architectures most commonly used in commercial spaces: self-contained lighting control, luminaire-integrated control, circuit-level control and networked control systems.



### SELF-CONTAINED CONTROLS

This is the simplest category of control. This category includes ON/OFF switches, dimmers, photo controls and occupancy sensors. Under the Energy Code, each area is required to be served by controls that allow occupants to adjust the lighting based on their needs.

### LUMINAIRE-INTEGRATED CONTROLS

Also known as on-board controls, these controls are integrated into the luminaire direct from the manufacturer. These controls typically address individual lights. Luminaires can come with occupancy or daylight harvesting controls.



### CIRCUIT-LEVEL CONTROL

This control strategy automatically addresses entire circuits serving lighting and certain plug loads, typically controlling them based on a programmed schedule or area occupancy.

The strategy can be implemented through a timer or time-clock feature that enables ON/OFF control based on a schedule defined by hours of building operation. Daylight harvesting and demand response control strategies also can be applied at the circuit level.

## NETWORKED CONTROL SYSTEMS

Networked lighting control systems can control select groups of luminaires or lighting for whole buildings, facilities or campuses. There are centralized, panel-based wired systems and distributed intelligence systems which are available in both wired and wireless forms. The number of lighting control networks and systems on the market has increased in recent years, with interfaces becoming increasingly user-friendly. These systems can integrate daylight harvesting, advanced scheduling, occupancy-based control, demand response and data monitoring.

Lighting also can be controlled as part of a computerized building management system (BMS) or energy management control system (EMCS) that can address HVAC and other systems in addition to lighting. Networked control systems may not override manual controls under the Energy Code.

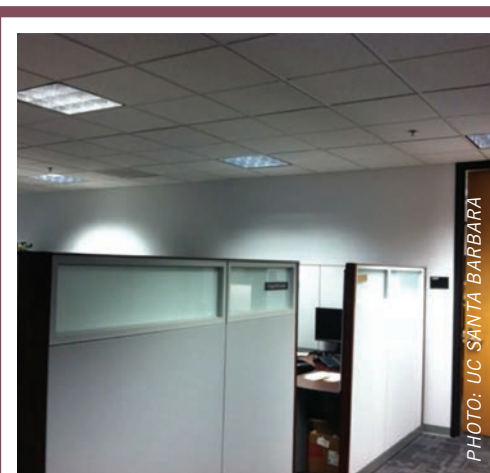
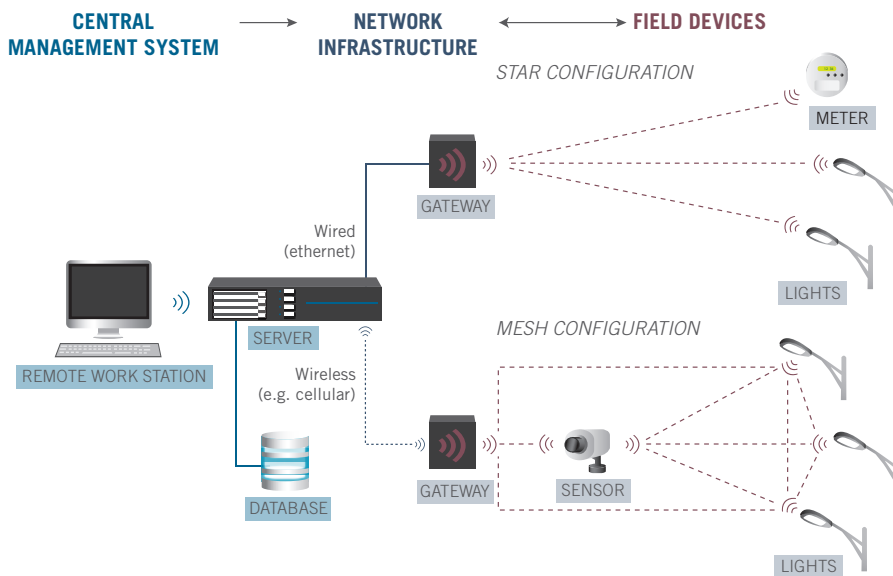

### THE BENEFITS OF NETWORKED CONTROLS IN OFFICE SPACES UC Santa Barbara, California

In 2013, UC Santa Barbara installed network-controlled LED lighting in the Student Information Systems & Technology Office through the State Partnership for Energy Efficient Demonstrations (SPEED) program. The project reduced lighting energy use by 89%, based on an average measured occupancy rate of 28%.

Each of the open office's 58 T8 fluorescent luminaires were replaced with a recessed LED luminaire and dimmable LED driver. The new luminaires were equipped with wireless occupancy sensors and wireless network lighting control units so they dim automatically when spaces are vacant. The control system software tracks energy use for the entire system and the individual luminaires. The new control system also allows for dimming, so light levels can be adjusted for specific cubicles and occupants' needs.

The occupancy data collected through the system has proven extremely valuable, informing occupancy rate studies and decision-making for HVAC retrofits and for lighting retrofits in other spaces. The occupancy data collected also has garnered better utility incentives for the campus.







## CHAPTER 4

# COMPLIANCE REQUIREMENTS

## COMPLIANCE OVERVIEW

There are two steps required to comply with the Energy Code.

1. Meet all **Mandatory requirements** by installing required devices, including controls, and ensure that they perform all required functions.
2. Select your method of compliance by choosing either the **Performance Approach** or the **Prescriptive Approach**.

### MANDATORY REQUIREMENTS

All nonresidential buildings must meet a set of Mandatory requirements for lighting systems and lighting controls. Examples of lighting system components addressed by Mandatory Measures include switching separation for certain light loads and use of automatic daylighting controls.

### PRESCRIPTIVE APPROACH

The Prescriptive Approach is a set of prescribed performance levels for various building components, where each component must meet the required minimum efficiency. This approach often is used in retrofit projects.

### PERFORMANCE APPROACH

The Performance Approach builds on the Prescriptive Approach by allowing energy allotments (defined in the Prescriptive requirements) to be traded between building systems, such as lighting, HVAC or the building envelope.

This compliance approach requires using energy analysis software approved by the Energy Commission to model the overall energy performance of a building. The Performance Approach often is used for New Construction projects.



#### APPROVED COMPUTER COMPLIANCE PROGRAMS

[www.energy.ca.gov/programs-and-topics/programs/building-energy-efficiency-standards/2019-building-energy-efficiency](http://www.energy.ca.gov/programs-and-topics/programs/building-energy-efficiency-standards/2019-building-energy-efficiency)

*Those following the Performance Approach to comply with the Energy Code must use software to model building energy use and that software must be approved by the Energy Commission.*

*More information on “Approved Computer Compliance Programs” is available through the Energy Commission’s website.*



## NAVIGATING THE ENERGY CODE: LIGHTING REQUIREMENTS

	Mandatory	Prescriptive	Performance
<b>NEW CONSTRUCTION: LIGHTING CONTROLS AND EQUIPMENT</b>	§ 130.0	§ 140.6(a)2 and § 140.6(d)	—
Manual Area Controls	§ 130.1(a)	—	—
Multi-level Controls	§ 110.9(b)3 and 130.1(b)	—	—
Automatic Shut-Off Controls: Time Switches and Occupant Sensing Controls	§ 110.9, § 130.1(c)	§ 140.6(a)2I	§ 140.6(a)2I
Automatic Daylighting Controls	§ 110.9, § 130.1(d)	§ 140.6(a)2H, § 140.6(d) and § 140.6(a)2L	§ 140.6(a)2H, § 140.6(d) and § 140.6(a)2L
Automated Demand Response	§ 110.12(a), § 110.12(c), and § 130.1(e)	§ 140.6(a)2K	§ 140.6(a)2K
Control Interactions	§ 130.1(f)	—	—
Institutional Tuning Controls	—	§ 140.6(a)2J	§ 140.6(a)2J
Lighting Controls Acceptance Tests	§ 130.4(a), § 130.4(c), NA 7.6, NA 7.7.5.2 and NA 7.8	—	—
<b>OUTDOOR LIGHTING</b>	§ 130.2	§ 140.7	—
<b>DAYLIGHTING/GLAZING REQUIREMENTS</b>	§ 110.6 and § 130.1(d)	§ 140.3, § 140.3(d)	—
Fenestration: Minimum U-factor, Solar Heat Gain Coefficient (SHGC), Visible Transmittance	§ 110.6(a)2 through § 110.6(a)6, § 110.6(b)	§ 140.3(a)5	—
Skylights: Maximum skylight to gross roof area, minimum SHGC, Visible Transmittance	—	§ 140.3(a)6	—
Minimum Daylight Requirements, spaces > 5,000 ft <sup>2</sup> with ceiling heights > 15 ft.	§ 130.1(d)	§ 140.3(c)	—



	Mandatory	Prescriptive	Performance
<b>CONTROLS DEVICES AND SYSTEMS, BALLASTS AND LUMINAIRES</b>	§ 110.9	—	—
Time-Switch Lighting Controls	§ 110.9(b)1	—	—
Daylighting Controls	§ 110.9(b)2	—	—
Dimmers	§ 110.9(b)3	—	—
Occupant Sensing Controls	§ 110.9(b)4 and § 110.9(b)6	—	—
Track Lighting Integral Current Limiter	§ 110.9(c)	—	—
Track Lighting Supplementary Overcurrent Protection Panel	§ 110.9(d)	—	—
<b>SIGN LIGHTING</b>	§ 130.3	§ 140.8	—
<b>ADDITIONS, ALTERATIONS AND REPAIRS</b>	—	—	—
Additions	§ 130.0 through § 130.5, as applicable	§ 141.0(a)1	§ 141.0(a)2
Alterations	§ 130.0 through § 130.5, as applicable	§ 141.0(b)2	§ 141.0(b)3 Table 141.0-E
Altered Indoor Lighting Systems	§ 130.1, as applicable per Table 141.0-F	§ 141.0(b)2I Table 141.0-F	§ 141.0(b)3 Table 141.0-E
Electrical Power Distribution Systems	—	§ 141.0(b)2P	—
Outdoor Lighting	—	§ 141.0(b)2L	—
Altered Sign Lighting	—	§ 141.0(b)2M	—
Repairs	§ 141.0(c)	—	—



## MANDATORY REQUIREMENTS FOR INDOOR LIGHTING

### REFERENCE ACE™ [energycodeace.com/content/reference-ace-2019-tool](http://energycodeace.com/content/reference-ace-2019-tool)

The Reference Ace™ tool helps users navigate the Energy Code documents. Keyword search capabilities along with hyperlinks allow users to jump directly to related sections.

The 2019 version of the Reference Ace links the relevant sections of the Energy Code, Reference Appendices, Residential and Nonresidential Compliance Manuals, and Residential and Nonresidential ACM Reference Manuals.



### BLUEPRINT NEWSLETTER [www.energy.ca.gov/newsroom/blueprint-newsletter](http://www.energy.ca.gov/newsroom/blueprint-newsletter)

The Energy Commission's Blueprint Newsletter is published by the Efficiency Division of the Energy Commission. Each edition offers information that is helpful in interpreting the Energy Code in professional practice. Topics are selected based on needs identified by the Energy Code hotline staff.

**BLUEPRINT**  
California Energy Commission  
Efficiency Division

Lighting control requirements constitute a large portion of the Mandatory lighting requirements contained in the Energy Code. The requirements for indoor lighting controls are included in **Section 130.1**. For New Construction projects, including Additions, all subsections within **Section 130.1** must be considered. Certain types of Alterations will trigger these requirements as well. Not all measures must be implemented in every project.

Determining what control measures will be required in a retrofit project is connected to the quantity of luminaires affected by the project, per enclosed space and the actual lighting energy use calculations. Some measures may be bypassed if the lighting power of a space is under certain lighting power thresholds defined by the Prescriptive requirements. Prescriptive lighting power allowance requirements are listed under **Section 140.6**.

Under the Energy Code, an alternate compliance option is available for lighting Alteration projects. Now, projects in small buildings or tenant spaces (5,000 ft<sup>2</sup> or less) that include one-for-one luminaire alterations to 50 or more luminaires can opt to retrofit with new luminaires that achieve at least 40% power reductions over pre-alteration luminaires. Multi-level light controls, automatic daylighting controls and demand responsive controls are not required for these projects.

While most requirement triggers are based on a percentage of affected luminaires or a percentage of an allowed LPD, the demand responsive controls requirements are additionally triggered by reaching an affected square footage threshold where the lighting power density is 0.5 watts per ft<sup>2</sup> or greater. New Construction and Alterations that involve 10,000 ft<sup>2</sup> or less of at least 0.5 watts per square foot within a single building are not required to comply with demand responsive controls requirements.

All lighting equipment and control devices specified to meet the requirements must be installed according to manufacturer's instructions and lighting controls should follow the Performance, acceptance testing and certification requirements listed in the Energy Code.



### Section 130.1–130.2

## LIGHTING CONTROLS

Mandatory lighting control requirements include provisions for the use of area controls, multi-level lighting, automatic shut-OFF controls, automatic daylighting controls and demand response control systems. These requirements apply to nearly all New Construction projects, both indoors and outdoors. Mandatory indoor requirements can be found in **Section 130.1**. Outdoor requirements are contained in **Section 130.2**. Acceptance test requirements are found in **Section 130.4** and acceptance test procedures in **Nonresidential Appendix (NA) 7.6, 7.7.5.2 and 7.8**.

### Section 130.1(a)

#### MANUAL AREA CONTROLS

The luminaires in each area must be independently controlled from luminaires in other areas by manual lighting controls that provide ON/OFF functionality.

The Energy Code calls for a manual switch to be readily accessible and located in the same room or area as the lighting it controls. Spaces that are exempt from the readily accessible requirement include public restrooms with two or more stalls, parking areas, stairwells and corridors. Spaces that are exempt from the requirement for controls to be located in the same room or area as the lighting it controls include malls and atria. The complete list is provided in the sidebar to the right. Although lighting control software applications for mobile devices are increasing in availability and lighting may be controllable through these points, it is still necessary to install a switch or device with ON/OFF functionality. Other installed controls may not override manual controls.

#### SEPARATE CONTROL OF DIFFERENT LIGHTING SYSTEMS

Within each area enclosed by ceiling-height partitions:

- General lighting must be controlled separately from all other lighting systems.
- Ornamental and display lighting, including lighting for floor and wall displays, window displays, case displays and special effects lighting, must each be separately controlled.

#### EXCEPTIONS: SECTION 130.1(a)2

*For malls and atria, auditorium areas, retail merchandise sales areas, wholesale showroom areas, commercial and industrial storage areas, general commercial and industrial work areas, convention centers, arenas, psychiatric and secure areas in healthcare facilities and other areas where placement of a manual area control poses a health and safety hazard, the manual area control may instead be located so that a person using the control can see the lights or area controlled by that control, or visually signal or display the current state of the controlled lighting.*

*In healthcare facilities, for restrooms and bathing rooms intended for a single occupant, the lighting control may be located outside the enclosed area but directly adjacent to the door.*

**EGRESS LIGHTING**

Up to 0.2 watts per ft<sup>2</sup> of indoor lighting may be continuously illuminated to allow for means of egress illumination consistent with **California Building Code Section 1008** in building spaces designated for emergency egress on building plans. This lighting is not required to comply with the manual area control requirements, and egress lighting controls cannot be accessible to unauthorized personnel.

# LIGHTING FOR MEANS OF EGRESS

Requirements Under California's Building Code and Energy Standards

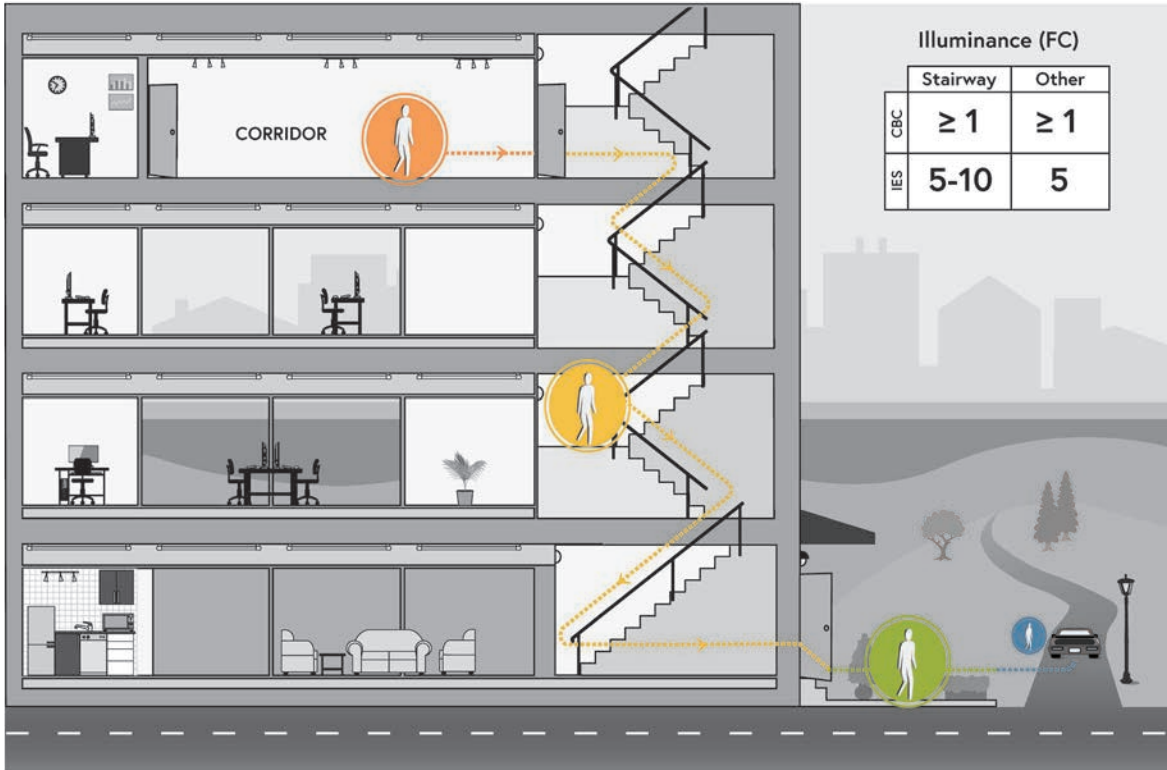

### Recommended Light Levels When Occupied

The Illuminating Engineering Society recommends that independent passageways and typical stairways be lit to five footcandles (fc) at the walking surface. High activity stairways are recommended to be lit to 10 fc.

#### Exit Access

That portion of a means of egress system that leads from any occupied portion of a building or structure to an exit.

#### Exit Discharge

That portion of a means of egress system between the termination of an exit and a public way.

#### Exit

That portion of a means of egress system between the exit access and the exit discharge or public way. Exit components include exterior exit doors at the level of exit discharge, interior exit stairways and ramps, exit passageways, exterior exit stairways and ramps and horizontal exits.

#### Public Way

A street, alley or other parcel of land open to the outside air leading to a street and is permanently appropriated for public use.

The requirements of CBC Section 1008 are applicable when applying mandatory partial-off occupancy control requirements from the Energy Standards, which means that the means of egress illumination levels shall not be less than 1 footcandle at the walking surface. This applies to the entire means of egress and includes: exit access, exit and the exit discharge spaces.

Partial-off occupancy controls (Energy Standards, Section 130.1(c)) are required for stairways and corridors (means of egress) in newly constructed buildings and lighting alterations in existing buildings. Partial-off occupancy controls reduce lighting power by at least 50% during vacant periods and automatically return to full output when someone is detected in the space. Even during vacant periods when lighting is reduced, it must provide at least 1 fc at the walking surface per CBC Section 1008.

Section 130.1(b)

**MULTI-LEVEL LIGHTING CONTROLS**

Dimmable lighting provides the opportunity to reduce lighting energy use while allowing occupants to choose an appropriate light level for each area at any time. The number of mandatory control steps is based on the light source type, per **Table 130.1-A**. If multi-level lighting is required, multi-level controls must allow the user to activate all the required control steps.

**MULTI-LEVEL LIGHTING CONTROL EXCEPTIONS:**

- Any area less than 100 ft<sup>2</sup>
- Connected lighting load of 0.5 W/ft<sup>2</sup> or less
- Any area enclosed by ceiling height partitions with only one luminaire and up to two lamps
- Restrooms
- Healthcare facilities
- Classrooms with general lighting that is 0.7 W/ft<sup>2</sup> or less and public restrooms only require one control step between 30 and 70% of full power, regardless of luminaire type
- Library stack aisles, aisle ways and open areas in warehouses, parking garages, parking areas, loading and unloading areas, stairwells and corridors only require one control step between 20 and 60% of full rated power, regardless of luminaire type

**Multi-level Lighting Controls and Uniformity Requirements for General Lighting**

Luminaire Type	Minimum Required Control Steps (percent of full rated power <sup>1</sup> )		Uniform Level of Illuminance Achieved By:	Common Use Cases
Line-voltage sockets except GU-24			Continuous Dimming 10–100%	Commercial applications, including recessed, downlight, accent and decorative
Low-voltage incandescent systems				
LED luminaires and LED source systems				
GU-24 rated for LED				
GU-24 sockets rated for fluorescent > 20W	2		Continuous Dimming 20–100%	Downlights
Pin-based compact fluorescent > 20W				
GU-24 sockets rated for fluorescent ≤ 20W	Minimum one step between 30–70%		Stepped dimming; continuous dimming; or switching alternate lamps in a luminaire.	Downlights, recessed
Pin-based compact fluorescent ≤ 20W				
Linear and U-bent fluorescent ≤ 13W				
Linear and U-bent fluorescent > 13W	Minimum one step in each range		Stepped dimming; continuous dimming; or switching alternate lamps in each luminaire, having a minimum of four lamps per luminaire, illuminating the same area and in the same manner.	Recessed, surface mount
	20–40%	50–70%		
	75–85%	100%		
Track Lighting	Minimum one step between 30–70%		Stepped dimming; continuous dimming; or separately switching circuits in a multi-circuit track with a minimum of two circuits.	Accent and decorative
HID > 20W	Minimum one step between 50–70%		Stepped dimming; continuous dimming; or switching alternate lamps in each luminaire, having a minimum of two lamps per luminaire, illuminating the same area and in the same manner.	High bay, low bay and outdoor
Induction > 25W				
Other Light Sources				

Table 130.1-A in the Energy Code

<sup>1</sup> Full rated input power of ballast and lamp, corresponding to maximum ballast factor.

<sup>2</sup> Includes only pin-based lamps: twin tube, multiple twin tube and spiral lamps.

NOTE: Multi-level controls must not override the functionality of other controls required for compliance.

**SHUT-OFF CONTROL EXCEPTIONS:**

- Lighting that is serving an area that is in continuous use, 24 hours per day 365 days per year
- Electrical equipment rooms
- Emergency lighting

**SHUT-OFF CONTROL SPECIAL CASES:**

The maximum size of the control zone increases to 20,000 ft<sup>2</sup> in:

- Malls
- Auditoriums
- Single tenant retail spaces
- Industrial facilities
- Convention centers and arenas

The override may exceed 2 hours in the following spaces if captive-key override is utilized:

- Malls
- Auditoriums
- Single tenant retail spaces
- Industrial spaces
- Arenas

**HEALTHCARE FACILITIES**

Healthcare facilities are exempt from all shut-OFF control requirements.

**Section 130.1(c)****SHUT-OFF CONTROLS**

Shut-OFF controls automatically reduce lighting power when a space is typically unoccupied. These controls are required in addition to the manual area lighting control and multi-level control requirements in **Section 130.1(a) and (b)**. For buildings not in continuous operation, almost all lighting should be OFF when a building is unoccupied. Lighting must be controlled by one or more of the following types of automatic shut-OFF controls:

- Automatic time switches
- Occupant sensing controls
- Other control capable of automatically shutting OFF all of the lighting when the space is typically unoccupied, such as an Energy Management Control System

Lighting in each enclosed area and every building floor (except in stairwells) must separately and automatically shut-OFF when the building is vacant. In addition, no more than 5,000 ft<sup>2</sup> may be covered by a single control. Again, up to 0.1 W/ft<sup>2</sup> may be left ON for building egress. Also, emergency lighting that is connected to a separate emergency power supply and is ON only when normal power fails is exempt from shut-OFF requirements.

**Countdown timer switches:** Countdown timer switches generally do not comply with shut-OFF requirements. However, they are allowed in the following specific applications:

- Closets smaller than 70 ft<sup>2</sup>
- Server aisles in server rooms

In these two areas, the timer switch must be programmed for a maximum time period of 10 minutes for closets and 30 minutes for server room aisles.



**Automatic Time-Switch Control:** Where time-switch controls are installed instead of occupant sensing controls, occupants must have a manual override option that allows the lighting to remain ON outside the scheduled time for a maximum of two hours, per **Section 130.1(c)3**, as well as automatic holiday shut-OFF, per **Section 130.1(c)4**. The automatic time-switch control may include a manual-ON mode.

**Occupant Sensing Controls Required:** When the following rooms are unoccupied, all the lighting should automatically be turned OFF by an occupant sensing control:

- Offices 250 ft<sup>2</sup> or less
- Multipurpose room less than 1,000 ft<sup>2</sup>
- Classrooms of any size
- Conference rooms of any size
- Restrooms of any size

The Energy Code also specifies how the lighting in these spaces can be activated by the occupancy sensor. For spaces that also require multi-level lighting controls, sensors must act as a partial-ON device or a vacancy sensor. The partial-ON strategy may only automatically activate between 50 and 70% of the controlled lighting power. For areas not required to have multi-level controls, the sensor may be a traditional auto-ON occupancy sensor, a vacancy sensor or employ a partial-ON strategy.

All controls must allow for lights to be manually shut-OFF regardless of sensor status.

## FULL OR PARTIAL-OFF OCCUPANCY CONTROLS

Full or partial-OFF occupancy controls are required in select areas. When a partial-OFF strategy is used, lighting systems must be reduced by at least 50% during vacant periods. This is in addition to meeting **Section 130.1(c)1**, which means that there must be an automatic shut-OFF control to turn lighting OFF when the space is typically unoccupied (e.g., after hours when the building is closed).

- Aisle ways and open areas in warehouses
- Library book stack aisles
- Corridors
- Stairwells

## PARTIAL-OFF OCCUPANCY CONTROLS

Parking garages, parking areas and loading/unloading areas must use a partial-OFF strategy. Additionally, common area corridors and stairwells that provide access to dwelling units in high-rise residential buildings and hotel or motel guest rooms must use a partial-OFF strategy. In these areas, lighting is not required to be fully shut OFF.

## HOTEL AND MOTEL GUEST ROOM CONTROLS

Hotel and motel guest rooms must use captive card-key controls, occupancy sensing controls or automatic controls to meet shut-OFF requirements. For hotel and motel guest rooms, the lighting must be shut OFF no more than 20 minutes after the room is vacated, even if occupancy sensing controls are used. One high-efficacy luminaire (as defined in **Table 150.0-A**) is exempt from these requirements so long as it is switched separately by a switch located within six feet of the entry door.

### EXCEPTIONS FOR WAREHOUSES

*In aisle ways and open areas in warehouses in which the installed lighting power is 80% or less of the value allowed under the Area Category Method, occupant sensing controls shall reduce lighting power by at least 40%.*

*When metal halide lighting or high pressure sodium lighting is installed in warehouses, occupant sensing controls shall reduce lighting power by at least 40%.*

### LIBRARY BOOK STACKS

*There are two library book stack aisle definitions that are required to use full or partial-OFF occupancy sensors:*

1. *Library book stack aisles that are at least 10 feet long and only accessible from one end*
2. *Library book stack aisles that are at least 20 feet long and accessible from both ends*

### PARTIAL-OFF OCCUPANCY CONTROL EXCEPTION:

*In corridors and stairwells in high-rise residential or hotel and motel buildings, in which the installed lighting power is 80% or less of the value allowed under the Area Category Method, occupant sensing controls shall reduce power by at least 40%.*

### MEANS OF EGRESS EXCEPTION:

*Lighting providing means of egress illumination shall be configured to provide at least the amount of light required by California Building Code Section 1008 while in the partial-OFF mode (see **page 38**).*

**Section 130.1(d)****DAYLIGHTING CONTROLS****DAYLIGHT COMMISSIONING**

*Proper calibration and commissioning of daylighting controls enables these devices to maintain a proper balance between daylight and electric lighting contributions.*

**EXCEPTIONS:****DAYLIGHTING CONTROL REQUIREMENTS**

- Rooms in which the combined total installed general lighting power in the skylit daylit zone and primary sidelit daylit zone is less than 120 watts are not required to meet the daylighting control requirements.
- General lighting in rooms with a total glazing area of less than 24 ft<sup>2</sup> are not required to meet the daylighting control requirements.
- Areas under skylights where it is documented that existing adjacent structures or natural objects block direct sunlight for more than 1,500 daytime hours per year between 8 A.M. and 4 P.M.
- Areas adjacent to vertical glazing below an overhang, where the overhang covers the entire width of the vertical glazing, and there is no vertical glazing above the overhang, and where the ratio of the overhang projection to the overhang rise is greater than 1.5 for South, East and West orientations or where the ratio of the overhang projection to the overhang rise is greater than 1 for North orientations.
- Luminaires in sidelit daylit zones in retail merchandise sales and wholesale showroom areas.

The Energy Code addresses three types of daylit zones:

1. **Skylit zones:** Areas illuminated by one or more skylights
2. **Primary sidelit zones:** Daylit areas directly adjacent to one or more windows
3. **Secondary sidelit zones:** Areas not directly adjacent to a window but close enough to still receive some daylight

**GENERAL LIGHTING IN DAYLIT ZONES**

Automatic daylighting controls are required for luminaires that meet these criteria:

- Provide general lighting (as opposed to display lighting, decorative chandeliers or ornamental lighting)
- Located at least partially in a skylit or primary sidelit zone
- Installed in rooms with a combined total installed general lighting power in the skylit daylit zones and primary sidelit daylit zones of 120 watts or more or in parking garages with a total installed general lighting power of 60 watts or more
- Located in a room with at least 24 ft<sup>2</sup> of glazing or a parking garage with at least 36 ft<sup>2</sup> of glazing or opening

Additionally, luminaires in skylit and primary sidelit daylit zones must be controlled separately from each other. Luminaires installed where a skylit and primary sidelit daylit zone overlap are controlled as part of the skylit daylit zone.

**DAYLIGHTING CONTROL REQUIREMENTS**

When compliance with this section is required, general lighting will be adjusted with automatic daylighting controls that:

- Provide multi-level lighting in accordance with **Table 130.1-A**
- Maintain design light levels for each space (i.e., at or above those provided by electric lighting when no daylight is available)
- Reduce general lighting power in a daylit zone at least 65% when the daylight contribution in that zone is more than 150% of the general lighting system's design light level at full power (for areas other than parking garages)

When photosensors are located within the daylit zone, at least one photosensor must be located so that they are not readily accessible to unauthorized personnel. The location where calibration adjustments are made to the automatic daylighting controls must be accessible to authorized personnel but may be inside a locked case or under a cover requiring a tool for access.

**PARKING GARAGES**

For parking garage areas with 36 ft<sup>2</sup> or more of glazing or opening, automatic daylighting controls shall be used to control luminaires that provide general lighting that are in the primary and secondary sidelit daylit zones. All primary and secondary sidelit daylit zones shall be shown on the plans.



Automatic daylighting controls in parking garages must be configured to operate according to the previously stated daylighting control requirements. They also must reduce general lighting power in a daylit zone to zero when illuminance levels measured at the farthest edge of the secondary sidelit zone away from the glazing or opening are greater than 150% of the controlled lighting's illuminance when no daylight is available. The combined illuminance from the controlled lighting and daylight shall not be less than the illuminance from controlled lighting when no daylight is available.

#### **DAYLIGHTING CONTROL REQUIREMENTS FOR ALTERATIONS**

In projects that qualify as Alterations, the daylighting requirements in this section often can be bypassed if the actual lighting power is 80% or lower of the lighting power allowance required using the Area Category Method. Additionally, only altered luminaires need to comply with the daylighting control requirements.

#### **PRESCRIPTIVE REQUIREMENTS**

When using the Prescriptive Approach to compliance, the requirements for automatic daylighting controls in primary sidelit daylit zones also apply to general lighting luminaires that are located in, or partially in, a secondary sidelit daylit zone.

Enclosed spaces with a roof, located in Climate Zones 2–15 that are larger than 5,000 ft<sup>2</sup> with a ceiling height greater than 15 feet and a lighting power density of 0.5 watts per square foot or more, must have at least 75% of their total floor area in daylit zones, per **Section 140.3(c)**.

#### **EXCEPTIONS: PARKING GARAGES**

- Luminaires located in the daylight adaptation zone and luminaires for only dedicated ramps. Daylight adaptation zone and dedicated ramps are defined in Section 100.1.
- Areas where the total combined general lighting power in the primary and secondary sidelit daylight zones is less than 60 watts.

#### **NONRESIDENTIAL COMPLIANCE MANUAL**

The Nonresidential Compliance Manual defines “partially in” as being at least 50% inside the secondary sidelit daylit zone.

#### **CALIFORNIA CLIMATE ZONES**

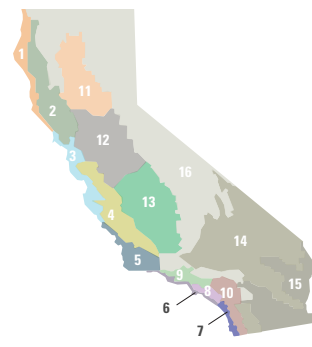

**EXCEPTION TO SKYLIT DAYLIT ZONES**

It is important to remember that areas under skylights where it is documented that existing adjacent structures or natural objects block direct sunlight for more than 1,500 daytime hours per year between 8 A.M. and 4 P.M. are exempt from daylighting requirements.

This can be documented to the local building official using a variety of tools including equipment that superimposes the sun path diagram on a photograph of the sky taken at the site, hand calculation tools such as the sun path calculator, and computer-aided design software tools that automate this calculation.

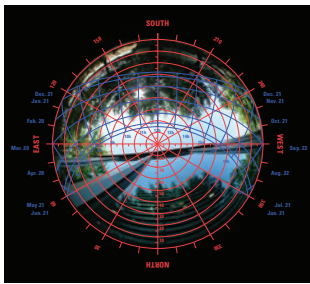

**DETERMINING DAYLIT ZONES**

All skylit daylit zones and primary sidelit daylit zones must be shown on building plans that are submitted for plan check when applying for a permit. Secondary sidelit daylit zones must also be shown on the plans when complying with Prescriptive requirements for automatic daylighting controls in secondary sidelit daylit zones. The easiest way to determine the size of daylit zones is examining building plans.

**CALCULATING A SKYLIT DAYLIT ZONE**

- 1. Define the shape of the skylight.** A rectangular skylight produces a rectangular daylight zone and a circular skylight produces a circular zone.
- 2. Determine the average ceiling height (CH) surrounding the skylight.** The ceiling height is the vertical distance from the finished floor level to the ceiling.
- 3. Multiply the CH by 0.7.**
- 4. Add the value determined in Step 3 in all directions around the skylight** (starting at the edges of the opening).
- 5. Subtract any area blocked from receiving daylight by a permanent obstruction taller than half of the distance from the floor to the bottom of the skylight.**

**DAYLIGHT HARVESTING FOR COMMERCIAL BUILDINGS GUIDE**

The Daylight Harvesting for Commercial Buildings Guide includes a description of the Energy Code and Appliance Efficiency Regulations, as well as design guidelines that can help make decisions to meet or exceed the Energy Code's performance goals. Regulations and design guidelines are organized along the seven building-related disciplines that affect daylight performance.



Obstruction height less than half the ceiling height

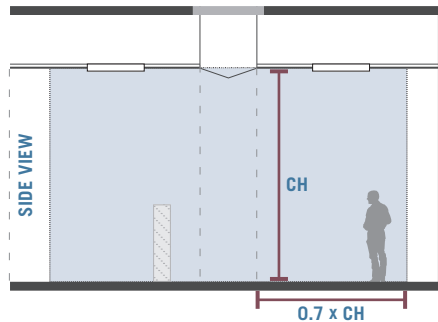

Obstruction height more than half the ceiling height

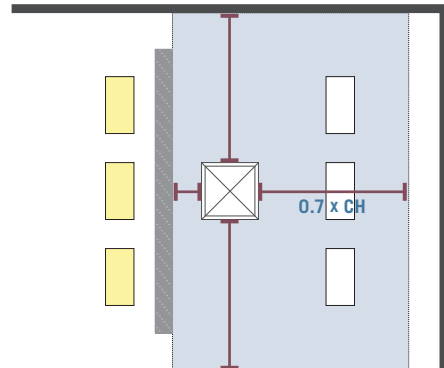
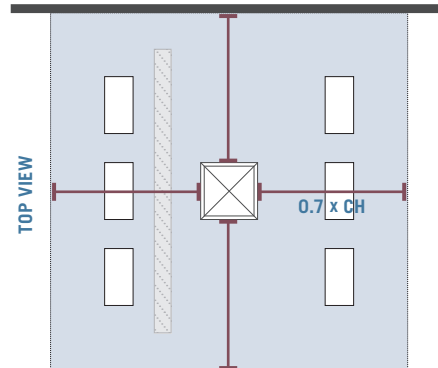
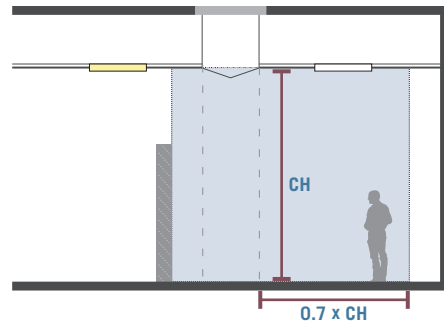



**CALCULATING A PRIMARY SIDELIT DAYLIT ZONE**

1. **Determine the window head height for each window.**  
The window head height (WHH) is the vertical distance from the finished floor level to the top of the glazing.
2. **Determine the depth of the zone.** The zone depth is one window head height into the area adjacent to the window.
3. **Calculate the width of the zone.** The zone width is the window’s width added to half the window head height on each side of the window.
4. Subtract any area blocked from receiving daylight by a permanent obstruction that is six feet or taller. Modular furniture is not considered a permanent obstruction.

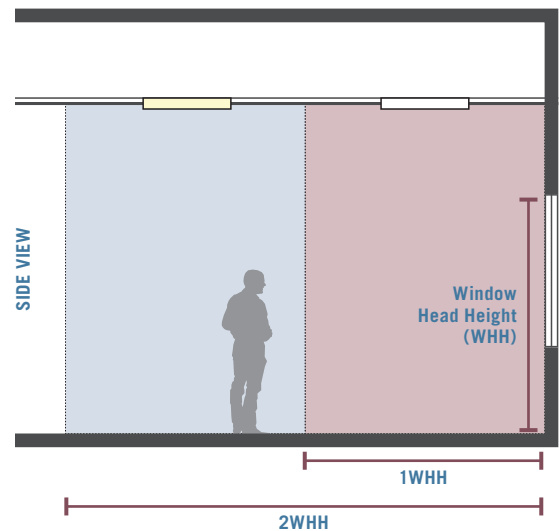

**EXCEPTION FOR SIDELIT DAYLIT ZONES**

*It is important to remember that areas adjacent to vertical glazing below an overhang, where the overhang covers the entire width of the vertical glazing, and there is no vertical glazing above the overhang, and where the ratio of the overhang projection to the overhang rise is greater than 1.5 for South, East and West orientations or where the ratio of the overhang projection to the overhang rise is greater than 1 for North orientations are exempt from daylighting requirements.*

(Where:  $\frac{x}{y} > 1.5$ )

Projection (x) : Rise (y)  
 > 1.5 for South, East, West orientations  
 > 1.0 for North orientations

### CALCULATING A SECONDARY SIDELIT DAYLIT ZONE

A secondary sidelit daylit zone extends one additional window head height beyond the primary sidelit daylit zone(s) adjacent to it.

1. Add one additional window head height to the depth of the primary sidelit daylit zone to determine the depth of the secondary sidelit daylit zone. The width of the secondary zone is the same as the width of the primary zone.
2. Subtract any area that is blocked from receiving daylight by a permanent obstruction that is six feet or taller.

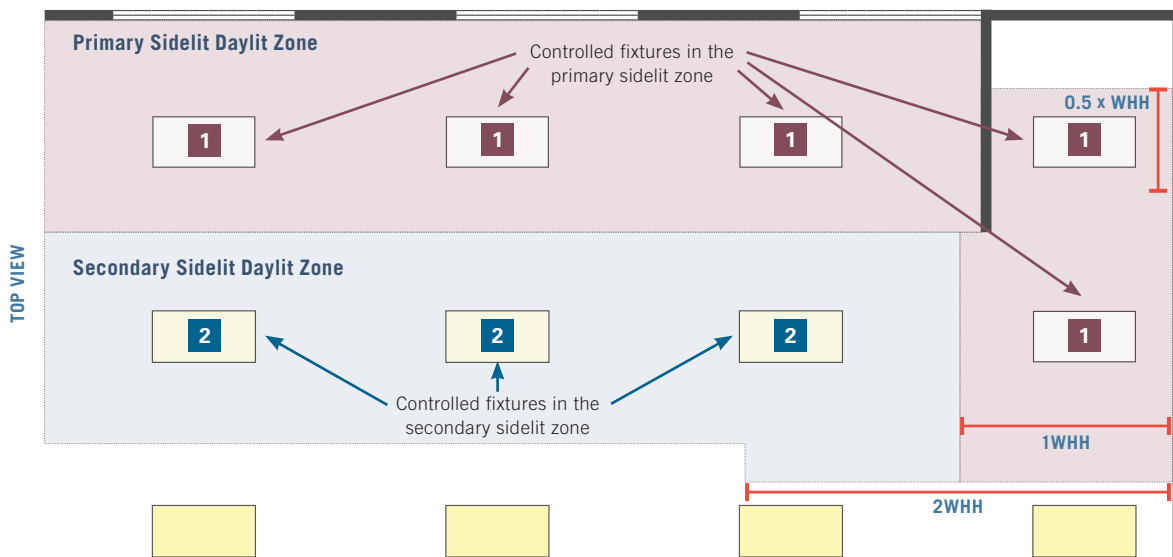

### Section 130.1(e) and Section 110.12 DEMAND RESPONSIVE CONTROLS

Starting with the 2019 Energy Code, demand responsive lighting control requirements are located in a new section in the sub-chapter for the manufacturing, construction and installation of systems, equipment and building components. Lighting demand responsive controls requirements are now listed under **Section 110.12—Demand Management**, which also include demand response (DR) requirements for other building systems, including air conditioning units and electronic message boards.

Automated demand response (ADR) programs use energy management technologies and controls to reduce peak demand and stabilize the grid more quickly and reliably than manual DR. An automated DR signal is sent from a utility, independent system operator or other power provider to energy management control systems enrolled in ADR programs. The automated systems then reduce electricity use temporarily, according to pre-programmed load shed strategies.

Buildings that have more than 10,000 ft<sup>2</sup> of space with a lighting power density greater than 0.5 W/ft<sup>2</sup> must include demand responsive controls that allow lighting power to be reduced automatically in response to a demand response signal consistent with requirements in **Table 130.1-A**. Spaces with a lighting power density of 0.5 W/ft<sup>2</sup> or less are not required to be equipped with demand responsive lighting controls.

#### EXCEPTION TO

#### DEMAND RESPONSE REQUIREMENTS:

*Spaces where a health or life safety statute, ordinance or regulation does not permit the lighting to be reduced are not required to install demand responsive controls and do not count toward the 10,000 ft<sup>2</sup> threshold.*

While the demand responsive controls are required by the Energy Code, participation in utility DR programs is not. Building owners have the option to enroll in DR programs.

Demand responsive lighting controls are required to either be a certified OpenADR 2.0a, OpenADR 2.0b Virtual End Node (VEN) or be certified by the manufacturer as being capable of responding to a DR signal from a certified OpenADR 2.0b VEN.

The Energy Code allows for the use of alternative communication protocols, so long as the system also uses one of the Mandatory protocols: Wi-Fi, ZigBee, BACnet, Ethernet or hard-wiring. This allowance is ideal for cloud-based systems that offer DR capabilities. When communications are disabled or unavailable, all DR controls must continue to perform all other control functions provided by the control **(Section 110.12(a)4)**.

For compliance testing, the lighting controls must be able to demonstrate a lighting power reduction in controlled spaces of at least 15% as compared to the total installed lighting power.

### Section 130.1(f)

## CONTROL INTERACTIONS

A new section has been added to the Energy Code defining the interactions of all mandatory indoor lighting controls (manual ON/OFF, multi-level lighting, shut-OFF controls, automatic daylighting controls and demand responsive controls). **Section 130.1(f)** outlines how each system should operate to ensure that all functions of the mandatory lighting controls are permitted or incorporated by the system as a whole.

1. For general lighting, the manual area control must permit the amount of light provided while the lighting is ON. General lighting can then be set, or adjusted, by the multi-level, shut-OFF, automatic daylighting and demand responsive controls specified in **Section 130.1(b), (c), (d) and Section 110.12**.
2. The manual area control must permit the shut-OFF control to turn the lighting down or OFF.
3. The multi-level lighting control must permit the automatic daylighting control to adjust the electric lighting level in response to changes in the amount of daylight in the daylit zone.
4. The multi-level lighting control must permit the demand responsive control to adjust the lighting during a demand response event and to return it to the level set by the multi-level control after the event.
5. The shut-OFF control must permit the manual area control to turn the lighting ON. If the ON request occurs while an automatic time-switch control would turn the lighting OFF, the ON request must be treated as an override request consistent with **Section 130.1(c)3**.
6. The automatic daylighting control must permit the multi-level lighting control to adjust the level of lighting.
7. For lighting controlled by multi-level lighting controls and by occupancy sensing controls with an automatic-ON function, the controls shall provide a partial-ON function that is capable of automatically activating between 50–70% of controlled lighting power.

### WHAT IS THE OPENADR ALLIANCE?

*The Energy Code requirements reference specific communication standards maintained by the OpenADR Alliance. The OpenADR Alliance standardizes, automates and simplifies demand response devices and distributed energy resources by establishing an open, highly secure, two-way information exchange standard.*



### CONSIDERATIONS FOR CONTROL INTERACTIONS

*Additional information on practical considerations for control interactions are provided in the **2019 Nonresidential Compliance Manual**.*



### CHECK YOUR UNDERSTANDING: MANDATORY CONTROLS IN PRACTICE

*At the end of this section is an exercise that reviews how the NRCC-LTI-E form documents lighting control requirements for lighting projects.*



*Section 130.2***MANDATORY REQUIREMENTS  
FOR OUTDOOR LIGHTING**

The Energy Code requirements for outdoor lighting apply to hardscape areas and other applications such as building façades. This typically consists of the paved, gravel or dirt portions of an outdoor building site but also may include planters or other small areas of landscaping within the application area. **Sections 110.9, 130.0, 130.2, 130.4 and 140.7** apply to newly constructed outdoor lighting systems. **Section 141.0** applies to outdoor lighting systems that are either Additions or Alterations.

The following outdoor lighting applications are regulated under the Energy Code:

Application	Energy Standards Section	
<b>General Illumination:</b> Building façade, parking lots, private roadways, driveways, sidewalks, walkways, bikeways and plazas (partial list)	<b>130.2</b>	Outdoor lighting controls and equipment
	<b>140.7</b>	Prescriptive requirements for outdoor lighting

Additional information on sign lighting for indoor and outdoor applications is provided in the Sign Lighting section on **page 83** of this guide.

*Section 10-114***LIGHTING ZONES****DARK-SKY ORDINANCES**

*A growing number of local governments have passed dark-sky ordinances that lower lighting power allowances as compared to the Energy Code. Check with the local permitting authority to determine if the project site's default Lighting Zone designation has been altered by local jurisdiction.*

*The Energy Commission must review and approve any changes to LZ designation. Local jurisdictions that have been approved by the Energy Commission and additional resources for creating a local ordinance are available at [localenergycodes.com](http://localenergycodes.com).*

Lighting Zones are based on the latest (2010) U.S. Census Bureau data. They are designed to help limit light pollution and ensure light levels are appropriate for the purposes different areas serve.

Beginning with the 2005 Energy Code cycle, the Energy Commission has specified lighting power allowances based on project locations and whether the surrounding environment is undeveloped wild (dark), rural (characterized by low ambient light levels) or urban (characterized by higher ambient light levels).

Lighting Zone 0 (LZO) is designated specifically for undeveloped areas in parks and preserves, where no continuous lighting is installed. While continuous lighting in LZO is explicitly prohibited, sites may utilize a single luminaire of 15W or less at entrances to parking lots, trail heads or other areas in order to safely illuminate site facilities. In addition, luminaires installed in LZO cannot exceed the maximum zonal lumen limits for backlight, upright and glare specified in **Section 130.2(b) and Title 24, Part 11, Section 5.106.8**.



Lighting Zone 1 (LZ1) maintains the lowest illumination level with the lowest lighting power allowances. This is the default designation for developed areas in government parks, recreation areas and wildlife preserves. Lighting Zone 2 (LZ2) is the state default designation for rural areas. Lighting Zone 3 (LZ3) is the state default designation for urban areas. There are no Lighting Zone 4 (LZ4) areas in California, but LZ4 allows the highest lighting power allowances.

To determine the Lighting Zone for a project, visit the U.S. Census Bureau's website, [factfinder.census.gov](http://factfinder.census.gov) or [data.census.gov](http://data.census.gov). Select Advanced Search, Geographies then the Address tab. Then enter the site address to determine if the site is in an urban area. If this is not indicated, the site is designated as rural.



**Lighting Zone 0 (LZ0)**  
Very Low: undeveloped open spaces



**Lighting Zone 1 (LZ1)**  
Low: parks and preserves



**Lighting Zone 2 (LZ2)**  
Moderate: rural areas

PHOTO: GREE, INC.

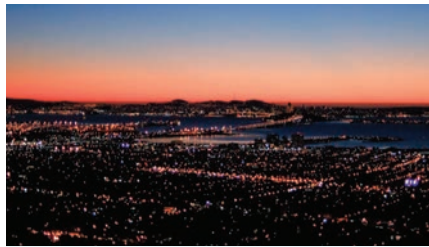

**Lighting Zone 3 (LZ3)**  
Moderately High: urban areas

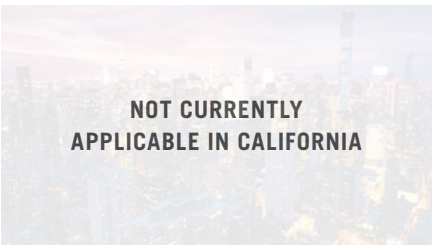

**NOT CURRENTLY  
APPLICABLE IN CALIFORNIA**

**Lighting Zone 4 (LZ4)**  
High

**NOTE:** LZ4 is not a default designation. LZ4 designation can be granted only by the Energy Commission when a local government applies for exceptionally high lighting power allowances.

**WHAT IS THE INTERNATIONAL DARKSKY ASSOCIATION (IDA)?**  
[darksky.org](http://darksky.org)

The International Dark-Sky Association works to protect the night skies for present and future generations. In 2011, IDA and the Illuminating Engineering Society of North America approved the Model Lighting Ordinance (MLO), an outdoor lighting template designed to help municipalities develop outdoor lighting standards that reduce glare, light trespass and skyglow.

Learn more about the MLO here:  
[www.darksky.org/our-work/lighting/public-policy/model-lighting-laws-policy/](http://www.darksky.org/our-work/lighting/public-policy/model-lighting-laws-policy/)

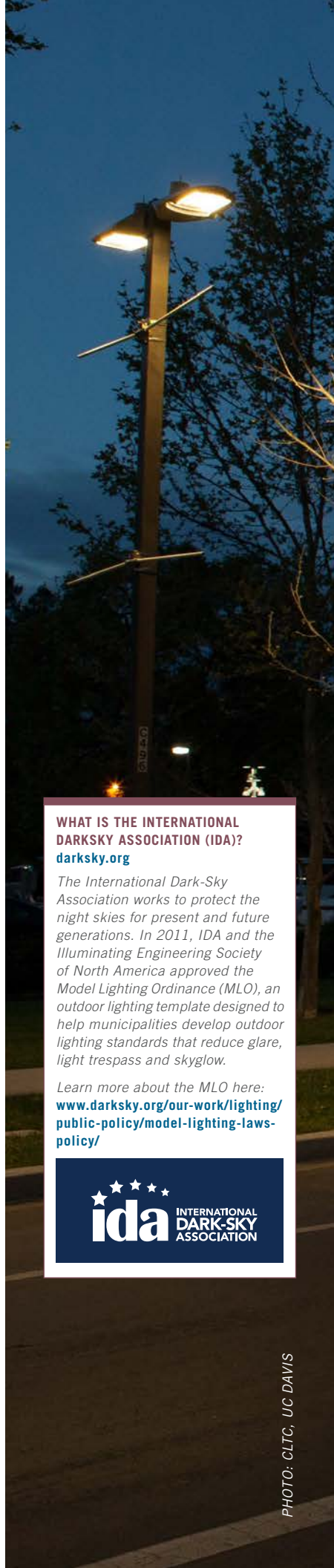

*Section 130.2(b)***BACKLIGHT, UPLIGHT AND GLARE (BUG) RATING SYSTEM****IES BUG RATING RESOURCES**  
[ies.org](http://ies.org)

More on how BUG ratings are calculated, along with tables and examples, can be found in IES Technical Memorandum TM-15-11, "Luminaire Classification System for Outdoor Luminaires."

A list of BUG ratings and tables can also be found at:  
[www.ies.org/wp-content/uploads/2017/03/TM-15-11BUGRatingsAddendum.pdf](http://www.ies.org/wp-content/uploads/2017/03/TM-15-11BUGRatingsAddendum.pdf).

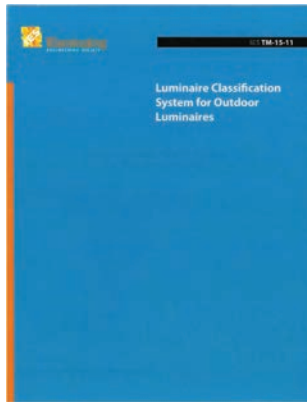

Conscientious lighting designers long have sought to minimize adverse effects of nighttime lighting with luminaires that limit backlight (or light trespass), uplight (sky glow or light pollution) and glare (high-angle brightness). The Illuminating Engineering Society (IES) began implementing the TM-15-11/BUG rating system in 2011 to supplement its older cutoff system of luminaire classification.

The BUG rating system helps lighting designers select luminaires that meet state and local requirements for different outdoor Lighting Zones (LZ0–LZ4). The BUG system also allows for better comparison of solid-state luminaires with traditional HID luminaires. The Energy Code includes requirements limiting backlight, uplight and glare in certain applications. These requirements are based on best practices for lighting different applications while minimizing light pollution and energy waste.

A BUG rating consists of three parts that indicate how well the luminaire controls backlight, uplight and glare. Lower ratings indicate minimal amounts of stray light, light pollution or glare and are appropriate for use in less populated Lighting Zone areas. The numeric BUG rating corresponds to the Lighting Zone where it is appropriate to install.

The best possible rating in each category is 0 (B0, U0 or G0). Higher ratings, the highest being 5 (B5, U5 or G5), indicate poorer control. For example, a luminaire rated B2-U0-G1 delivers mediocre control of backlight, offers excellent control of uplight, and controls glare well.

BUG ratings correspond with the amount of light emitted at each secondary solid angle within the backlight, uplight or glare angles. **Title 24, Part 11, Section 5.106.8** (CALGreen) lists the zonal lumen maximums allowed for backlight, uplight and glare within each outdoor Lighting Zone and are provided on the next page of this guide. The BUG ratings for outdoor luminaires are included in most manufacturers' photometric reports.

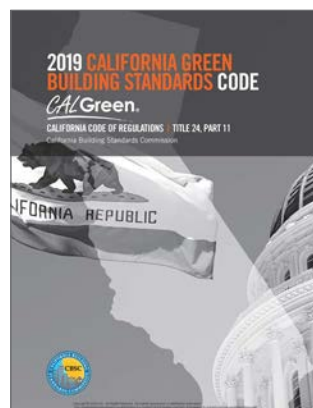
**WHAT IS CALGREEN?**

CALGreen, also known as Title 24, Part 11, was developed in an effort to meet the California Global Warming Solutions Act of 2006 (AB 32). The purpose of CALGreen is to improve public health, safety and general welfare by enhancing the design and construction of buildings through the use of building concepts having a reduced negative impact or increased positive environmental impact and encouraging sustainable construction practices.

The backlight, uplight and glare requirements for outdoor lighting are contained in CALGreen as part of the light pollution reduction section.

Detailed information on how to effectively comply with CALGreen can be found here:

[codes.iccsafe.org/content/chapter/15778](http://codes.iccsafe.org/content/chapter/15778).

**Maximum Allowable Backlight, Uplight and Glare (BUG) Ratings<sup>1,2</sup>**

Allowable Rating	LZ0	LZ1	LZ2	LZ3	LZ4
<b>Maximum Allowable Backlighting Rating<sup>3</sup> (B)</b>					
Luminaire greater than 2 mounting heights (MH) from property line	N/A	No Limit	No Limit	No Limit	No Limit
Luminaire back hemisphere is 1–2 MH from property line	N/A	B2	B3	B4	B4
Luminaire back hemisphere is 0.5–1 MH from property line	N/A	B1	B2	B3	B3
Luminaire back hemisphere is less than 0.5 MH from property line	N/A	B0	B0	B1	B2
<b>Maximum Allowable Uplight Rating (U)</b>					
For area lighting <sup>4</sup>	N/A	U0	U0	U0	U0
For all other outdoor lighting, including decorative luminaires	N/A	U1	U2	U3	U4
<b>Maximum Allowable Glare Rating<sup>5</sup> (G)</b>					
Luminaire greater than 2 MH from property line	N/A	G1	G2	G3	G4
Luminaire front hemisphere is 1–2 MH from property line	N/A	G0	G1	G1	G2
Luminaire front hemisphere is 0.5–1 MH from property line	N/A	G0	G0	G1	G1
Luminaire front hemisphere is less than 0.5 MH from property line	N/A	G0	G0	G0	G1

*Based on Table 5.106.8 from CALGreen*

<sup>1</sup> IESNA Lighting Zones 0 are not applicable; refer to Lighting Zones as defined in the California Energy Code and Chapter 10 of the California Administrative Code.

<sup>2</sup> For property lines that abut public walkways, bikeways, plazas and parking lots, the property line may be considered to be 5 feet beyond the actual property line for purpose of determining compliance with this section. For property lines that abut public roadways and public transit corridors, the property line may be considered to be the centerline of the public roadway or public transit corridor for the purpose of determining compliance with this section.

<sup>3</sup> If the nearest property line is less than or equal to two mounting heights from the back hemisphere of the luminaire distribution, the applicable reduced Backlight rating shall be met.

<sup>4</sup> General lighting luminaires in areas such as outdoor parking, sales or storage lots shall meet these reduced ratings. Decorative luminaires located in these areas shall meet U-value limits for "all other outdoor lighting."

<sup>5</sup> If the nearest property line is less than or equal to two mounting heights from the front hemisphere of the luminaire distribution, the applicable reduced Glare rating shall be met.

**Backlight Ratings (Maximum Zonal Lumens)**

Secondary Solid Angle	Maximum Zonal Lumens per Outdoor Lighting Zone				
	LZO (B0)	LZ1 (B1)	LZ2 (B2)	LZ3 (B3)	LZ4 (B4)
<b>Backlight High (BH)</b> 60 to 80 degrees	110	500	1,000	2,500	5,000
<b>Backlight Medium (BM)</b> 30 to < 60 degrees	220	1,000	2,500	5,000	8,500
<b>Backlight Low (BL)</b> 0 to < 30 degrees	110	500	1,000	2,500	5,000

**Uplight Ratings (Maximum Zonal Lumens)**

Secondary Solid Angle	Maximum Zonal Lumens per Outdoor Lighting Zone				
	LZO (U0)	LZ1 (U1)	LZ2 (U2)	LZ3 (U3)	LZ4 (U4)
<b>Uplight High (UH)</b> 100 to 180 degrees	0	10	50	500	1,000
<b>Uplight Low (UL)</b> 90 to < 100 degrees	0	10	50	500	1,000

**Glare Ratings (Maximum Zonal Lumens)**

GLARE RATING FOR ASYMMETRICAL LUMINAIRE TYPES (TYPE I, TYPE II, TYPE III, TYPE IV)					
Secondary Solid Angle	Maximum Zonal Lumens per Outdoor Lighting Zone				
	LZO (G0)	LZ1 (G1)	LZ2 (G2)	LZ3 (G3)	LZ4 (G4)
<b>Forward Very High (FVH)</b> 80 to 90 degrees	10	100	225	500	750
<b>Backlight Very High (BVH)</b> 80 to 90 degrees	10	100	225	500	750
<b>Forward High (FH)</b> 60 to < 80 degrees	660	1,800	5,000	7,500	12,000
<b>Backlight High (BH)</b> 60 to < 80 degrees	110	500	1,000	2,500	5,000
GLARE RATING FOR QUADRILATERAL SYMMETRICAL LUMINAIRE TYPES (TYPE V, TYPE V SQUARE)					
Secondary Solid Angle	Maximum Zonal Lumens per Outdoor Lighting Zone				
	LZO (G0)	LZ1 (G1)	LZ2 (G2)	LZ3 (G3)	LZ4 (G4)
<b>Forward Very High (FVH)</b> 80 to 90 degrees	10	100	225	500	750
<b>Backlight Very High (BVH)</b> 80 to 90 degrees	10	100	225	500	750
<b>Forward High (FH)</b> 60 to < 80 degrees	660	1,800	5,000	7,500	12,000
<b>Backlight High (BH)</b> 60 to < 80 degrees	660	1,800	5,000	7,500	12,000

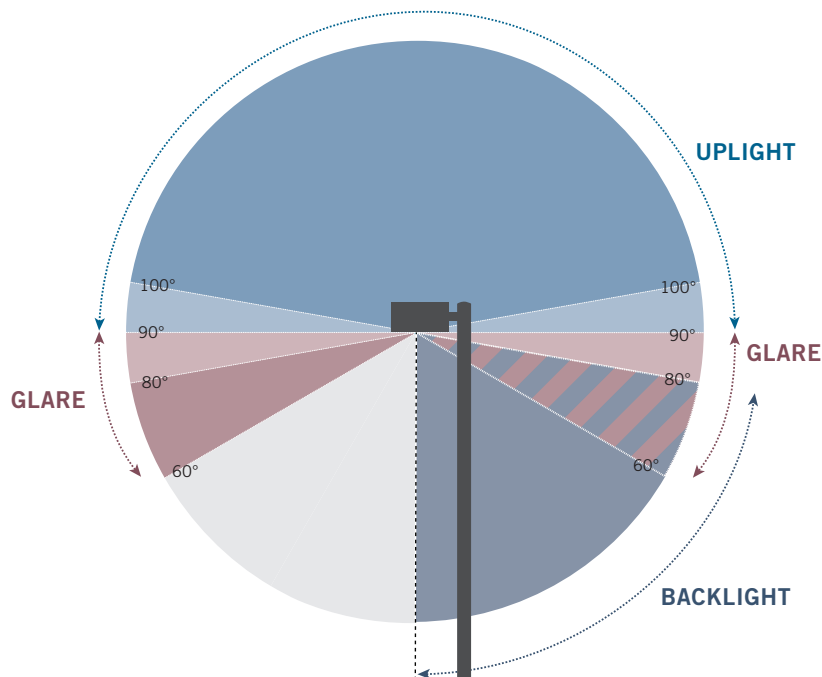

Uplight is defined as excess lighting directed up into the night sky, above 90 degrees. This causes light pollution, or artificial sky glow.

Glare is caused by light emitted between 60 and 90 degrees around a luminaire. Light emitted at these angles can be uncomfortable and even hazardous.

Backlight includes all illumination behind a luminaire. Backlight causes light trespass, which occurs when light spills into unwanted areas.

## COMPLIANCE REQUIREMENTS

**Applications with BUG Limits:** Outdoor luminaires rated greater than 6,200 lumens must comply with backlight, uplight and glare limitations if installed in nonresidential, high-rise residential and hotel or motel buildings.

**Applications without BUG Limits:** Lamps and luminaires in these applications are not required to comply with BUG requirements:

1. Signs
2. Building façades, public monuments, statues and vertical surfaces of bridges
3. Lighting not permitted by a health or life safety statute, ordinance or regulation to be a cutoff luminaire
4. Temporary lighting
5. Replacement pole-mounted luminaires in areas where all of the following are true:
  - Connected lighting power is not increased
  - No new wiring is being installed
  - No additional poles are being added
  - Spacing between poles is greater than six times the mounting height of the existing luminaires
  - Existing luminaire does not meet the luminaire BUG requirements
6. Luminaires that illuminate the public right of way on publicly maintained roadways, sidewalks and bikeways
7. Outdoor lighting attached to a high-rise residential, hotel or motel building and separately controlled from the inside of a dwelling unit or guest room

The Energy Code does not require luminaires selected for these purposes to comply with BUG limits, but best practices dictate limiting light trespass and preserving dark skies whenever possible.

### REMINDER FOR BUG REQUIREMENTS:

*It is important to remember that BUG requirements must be met if the luminaire is greater than 6,200 lumens. This applies even when a project is exempt from wattage allowances (see Section 140.7(a)) and for all Alterations of any size.*

## REQUIRED OUTDOOR LIGHTING CONTROLS

### EXCEPTIONS:

#### OUTDOOR LIGHTING CONTROLS

*Outdoor lighting not permitted by a health or life safety statute, ordinance or regulation to be turned OFF or reduced is exempt from these requirements.*

*Lighting in tunnels required to be illuminated 24 hours per day and 365 days per year.*

### Section 130.2(c)1, 130.2(c)2

#### ALL OUTDOOR LIGHTING

Outdoor lighting must be independently controlled from other electrical loads, and the controls must meet the following requirements in **Section 130.2(c)1** and **Section 130.2(c)2**.

All outdoor lighting must be equipped with photo controls, astronomical time switch devices or other controls capable of automatically shutting OFF all lighting when sufficient daylight is available.

Automatic scheduling controls are required for all outdoor lighting and may be installed in combination with motion sensing controls or other outdoor lighting controls. The automatic scheduling controls must have the following capabilities:

- Reduce outdoor lighting power by at least 50% but no more than 90% and be capable of turning the lighting OFF separately during scheduled unoccupied periods
- Allow scheduling of a minimum of two nighttime periods with independent lighting levels and may include an override function that turns lighting ON during its scheduled dim or OFF state for no more than two hours when an override is initiated
- Pass the required Acceptance Tests for outdoor lighting controls in **Section 130.4(a)6**

Using part-night outdoor lighting controls can fulfill the automatic scheduling control requirements.

### Section 110.9(b)5

#### PART-NIGHT OUTDOOR LIGHTING CONTROL REQUIREMENTS

A part-night lighting control is a time-based or occupancy-based device programmed to reduce or turn OFF power to an outdoor luminaire for a portion of the night. To be in compliance, part-night controls must:

1. Predict sunrise and sunset within 15 minutes using both light sensing and time measurement
2. Be able to reduce or turn OFF outdoor luminaire power at night
3. Be programmable by users so outdoor luminaire power can be reduced or turned OFF at any time as determined by the user

Time-based scheduling control can be relative to both sunset and sunrise, and to the midpoint between sunset and sunrise.

### Section 130.2(c)3

#### MOTION SENSING CONTROLS

Motion sensing controls are required to be installed in combination with the following luminaires:

- Outdoor luminaires where the bottom of luminaire is mounted 24 feet or less

### OUTDOOR LUMINAIRES

*Where the bottom of an outdoor luminaire is mounted 24 feet above grade or lower, the luminaire must be controlled by a motion sensing control that automatically reduces lighting power by 50–90% during vacant periods. If the luminaire is 40 watts or less, it is exempt.*



above grade; building façade, ornamental hardscape, outdoor dining lighting and outdoor sales frontage lighting are exempt

- Outdoor wall mounted luminaires installed for building façade, ornamental hardscape or outdoor dining lighting that have a bilaterally symmetric distribution, as described in the IES Handbook (typically referred to as “wall packs”), mounted 24 feet above grade or lower

Motion sensing controls may be installed for other outdoor lighting and in combination with other outdoor lighting controls. Motion sensing controls shall be capable of:

- Reducing the outdoor lighting power of each controlled luminaire by at least 50% but no more than 90%
- Turning the luminaire OFF during unoccupied periods
- Reducing the lighting to its dim or OFF state no longer than 15 minutes after the area has been vacated
- Returning the lighting to its ON state when the area becomes occupied

No more than 1,500 watts of lighting power shall be controlled by a single sensor.

#### EXCEPTIONS

1. Luminaires with a maximum rated wattage of 40 watts each are not required to have motion sensing controls.
2. Applications also listed as exceptions to **Section 140.7(a)**.
3. Lighting subject to a health or life safety statute, ordinance or regulation may have a minimum time-out period longer than 15 minutes or a minimum dimming level above 50% when necessary to comply with the applicable law.

#### Section 130.4

## LIGHTING CONTROLS ACCEPTANCE TESTING

Lighting control systems must be tested by a certified lighting controls acceptance test technician after they are installed and commissioned. Acceptance tests are required under the Energy Code and ensure that controls operate in accordance with the Energy Code requirements. Both indoor and outdoor lighting control systems must be tested. Functional test results also must be included in commissioning documents when required under **Section 120.8**.

Acceptance testing is required for the following lighting control systems:

- Automatic daylighting controls
- Shut-OFF controls
  - Occupancy sensing controls and time-switch controls
- Demand responsive controls
- Institutional tuning controls used to earn a power adjustment factor (PAF)
- Outdoor lighting controls
  - Motion sensing controls, photo controls, astronomical time-switch controls and automatic scheduling controls

Acceptance testing also is required for daylighting envelope features, documented in NRCA-ENV-03-F.

#### ACCEPTANCE TESTING (AT) TECHNICIAN TRAINING

CALCTP ([calctp.org](http://calctp.org)) and NLCAA ([nlcaa.org](http://nlcaa.org)) are two training and certification programs recognized and approved by the Energy Commission to carry out lighting controls acceptance testing as required by the Energy Code.

#### EXCEPTION: LIGHTING CONTROLS ACCEPTANCE REQUIREMENTS

Lighting control acceptance requirements apply to nonresidential buildings other than healthcare facilities, high-rise residential buildings and hotel or motel buildings.

Healthcare facilities must comply with the applicable requirements of OSHPD.

#### ACCEPTANCE TESTING REQUIREMENTS FOR ALTERATIONS

Acceptance testing requirements are not required for indoor or outdoor Alteration projects where controls are added to 20 or fewer luminaires.



*Section 130.5*

## MANDATORY REQUIREMENTS FOR ELECTRICAL POWER DISTRIBUTION SYSTEMS

The Energy Code regulates certain aspects of electrical power distribution systems. These requirements are intended to improve building energy efficiency by providing the electrical infrastructure necessary to enable energy use metering and plug-load shut-OFF controls. When building owners and operators can understand the energy use of specific building systems and appliances, they can more easily make decisions regarding efficiency programs and upgrades. With the advent of smart meters, energy data is now readily available. By ensuring that individual loads are capable of being separately monitored and controlled, building energy efficiency can be improved greatly. These Mandatory requirements apply to New Construction, Additions and select Alterations.

*Table 130.5-A*

### SERVICE ELECTRICAL METERING

A building's electrical service must have an electrical metering system to measure instantaneous demand and electrical energy use. The electrical service meter must display instantaneous demand in kW and measure kWh usage over time for a user-definable period. This applies to New Construction and Alterations with new service electrical metering.

Larger services rated greater than 250kVA require historical peak demand in kW. Larger services rated more than 10,000kVA require kWh per rate period.

Utility-provided "smart meters" usually meet the requirements as long as they can measure instantaneous demand and energy use over a utility-defined period.

*Table 130.5-B*

### SEPARATION OF ELECTRICAL LOADS FOR ELECTRICAL ENERGY MONITORING

Requirements for separation of electrical load types are based on the rating of the building's electrical service. The separation of electrical loads, when required, is intended to allow for measurement devices to be able to monitor electrical energy usage for different load types.

All services require renewables and electric vehicle charging to be separated. For services up to 50kVa, no additional separation is required. Buildings with an electrical service rated greater than 50kVA are required to separate additional load types. Buildings must be wired to be capable of monitoring load types separately. This requirement does not require any metering. By placing all loads of a particular type on one feeder or separating loads per branch circuit, a portable device can be temporarily attached to that feeder to allow for measurements. This is a Mandatory requirement and will affect newly constructed buildings. For Alterations, the requirements will apply to entirely new or complete replacement of the electrical power distribution system. If the switchboard, feeders, panel boards and branch circuits remain unchanged, this requirement is not triggered.

**EXCEPTION:****SERVICE ELECTRICAL METERING**

*Electrical power distribution systems in healthcare facilities (as defined by California Electrical Code Article 517) are subject to the Electrical Code.*



**Table 130.5-A: Minimum Requirements for Metering of Electrical Load**

Metering Functionality	Electrical Services rated 50kVA or less	Electrical Services rated more than 50kVA and less than or equal to 250kVA	Electrical Services rated more than 250kVA and less than or equal to 1000kVA	Electrical Services rated more than 1000kVA
Instantaneous (at the time) kW demand	Required	Required	Required	Required
Historical peak demand (kW)	Not required	Not required	Required	Required
Tracking kWh for a user-definable period	Required	Required	Required	Required
kWh per rate period	Not required	Not required	Not required	Required

**Table 130.5-B: Minimum Requirements for Separation of Electrical Load**

Electrical Load Type	Electrical Services rated 50kVA or less	Electrical Services rated more than 50kVA and less than or equal to 250kVA	Electrical Services rated more than 250kVA and less than or equal to 1000kVA	Electrical Services rated more than 1000kVA
Lighting including exit and egress lighting and exterior lighting	Not required	All lighting in aggregate	All lighting disaggregated by floor, type or area	All lighting disaggregated by floor, type or area
HVAC systems and components including chillers, fans, heaters, furnaces, package units, cooling towers and circulation pumps associated with HVAC	Not required	All HVAC in aggregate	All HVAC in aggregate and each HVAC load rated at least 50kVA	All HVAC in aggregate and each HVAC load rated at least 50kVA
Domestic and service water system pumps and related systems and components	Not required	All loads in aggregate	All loads in aggregate	All loads in aggregate
Plug load including appliances rated less than 25kVA	Not required	All plug load in aggregate	All plug load separated by floor, type or area	All plug load separated by floor, type or area
		Groups of plug loads exceeding 25kVA connected load in an area less than 5,000 ft <sup>2</sup>	Groups of plug loads exceeding 25kVA connected load in an area less than 5,000 ft <sup>2</sup>	All groups of plug loads exceeding 25kVA connected load in an area less than 5,000 ft <sup>2</sup>
Elevators, escalators, moving walks and transit systems	Not required	All loads in aggregate	All loads in aggregate	All loads in aggregate
Other individual non-HVAC loads or appliances rated 25kVA or greater	Not required	All loads in aggregate	All loads in aggregate	All loads in aggregate
Industrial and commercial load centers 25kVA or greater including theatrical lighting installations and commercial kitchens	Not required	All loads in aggregate	All loads in aggregate	All loads in aggregate
Renewable power source (net or total)	Each group	Each group	Each group	Each group
Loads associated with renewable power source	Not required	All loads in aggregate	All loads in aggregate	All loads in aggregate
Charging stations for electric vehicles	All loads in aggregate	All loads in aggregate	All loads in aggregate	All loads in aggregate

## VOLTAGE DROP

The maximum combined voltage drop on both installed feeder conductors and branch circuit conductors to the farthest connected load or outlet cannot exceed 5%. Exceptions to **Section 130.5(c)** are voltage drops permitted by **Sections 647.4, 695.6 and 695.7 of the California Electrical Code** for sensitive electronic devices, fire pump transformers and fire pump power wiring. This applies to New Construction projects as well as Alteration projects that add, modify or replace feeder and branch circuits. For these Alterations, requirements only apply to the altered circuits (**Section 141.0(b)2P**).

## CIRCUIT CONTROLS FOR 120-VOLT RECEPTACLES

In New Construction, Alterations where the entire electrical power distribution system is replaced and spaces being built out for the first time such as a tenant improvement (TI), both controlled and uncontrolled 120 volt receptacles must be provided in office areas, lobbies, conference rooms, kitchen areas in office spaces and copy rooms. Licensed healthcare facilities are exempt from these requirements.

Controlled receptacles must meet all of the following requirements, as applicable:

1. Install a control, such as automatic time-switch or occupancy sensor, capable of automatically shutting OFF the controlled receptacles when the space is typically unoccupied, either at the receptacle or circuit level.
  - When an automatic time-switch control is installed, it must use an override control that allows the controlled receptacle to remain ON for no more than 2 hours when an override is initiated and an automatic holiday “shut-OFF” feature that turns OFF all loads for least 24 hours and then resumes the normally scheduled operation.
  - Countdown timer switches cannot be used to comply with the automatic time-switch control requirements.
2. Install at least one controlled receptacle within six feet from each uncontrolled receptacle or install a split-wired receptacle with at least one controlled and one uncontrolled receptacle. Where receptacles are installed in modular furniture in open office areas, at least one controlled receptacle shall be installed at each workstation.
3. Provide a permanent marking for controlled receptacles or circuits to differentiate them from uncontrolled receptacles or circuits.

### EXCEPTIONS: SECTION 130.5(D)

**Exception 1:** Receptacles used for the following purposes are exempt from Section 130.5(d) requirements:

- Receptacles specifically for refrigerators and water dispensers in kitchen areas
- Receptacles located a minimum of six feet above the floor that are specifically for clocks
- Receptacles for network copiers, fax machines, A/V and data equipment other than personal computers in copy rooms
- Receptacles on circuits rated more than 20 amperes.
- Receptacles connected to an uninterruptible power supply (UPS) that are intended to be in continuous use, 24 hours per day/365 days per year, and are marked to differentiate them from other uncontrolled receptacles or circuits.

**Exception 2:** Receptacles in healthcare facilities.

### HARDWIRED POWER STRIPS

A hardwired power strip controlled by an occupant sensing control may be used to comply with these requirements. Plug-in strips and other plug-in devices cannot.

For entirely new or complete replacement of electrical power distribution systems in Alteration projects, the entire system shall meet these requirements.

For hotel and motel guest rooms, install controlled receptacles for at least one-half of the 120 volt receptacles in each guest room. Electric circuits serving controlled receptacles in guest rooms shall have captive card key controls, occupancy sensing controls or automatic controls so the power is switched OFF no longer than 30 minutes after the guest room has been vacated.

## PERFORMANCE APPROACH

The Performance Approach to compliance is a software-based method that uses energy modeling to plan for an energy-efficient building. This method is more commonly used in New Construction projects.

### SYSTEM TRADE-OFFS ALLOWED

In addition to meeting Mandatory requirements, actual lighting power may not exceed the lighting power allowances set forth by the Energy Code, unless traded with other energy features of the building using the Performance Approach.

Under the Performance Approach, trade-offs may be made between different systems within a building. For example, use of energy-efficient indoor lighting can allow more flexibility for other Prescriptive requirements. There is no trade-off benefit to using this method on projects that only affect the lighting system. It is important to note that outdoor lighting and indoor lighting are not allowed system trade-offs, and that the Prescriptive secondary daylighting controls can only be traded using the detailed software options (e.g., IESVE, CBECC/SketchUp).

The Performance Approach is recommended for professionals with experience using software modeling to manage energy budgets.

### APPROVED SOFTWARE REQUIRED

Those choosing the Performance Approach must use software to model building energy use, and that software must be approved by the Energy Commission.

## PRESCRIPTIVE APPROACH FOR INDOOR LIGHTING

When using the Prescriptive Approach to lighting power compliance for New Construction, choose one of the following methods to calculate the allowed indoor lighting power for each room or area of a building:

1. Complete Building Method
2. Area Category Method
3. Tailored Method

All three methods involve multiplying the area of a space (ft<sup>2</sup>) by the allowed lighting power density (W/ft<sup>2</sup>) for that space and adding special allowances such as display lighting and decorative or ornamental lighting. Adjusted lighting power, which includes the use of power adjustment factors, select lighting wattage exclusions and luminaire classification and power adjustments, may not exceed this allowance.

With the Prescriptive Approach, trade-offs are limited to general lighting power and restricted to certain space types. Under this approach, the actual lighting power is compared to an allowed lighting power total. If the actual lighting power is less than or equal to the allowed lighting power, the project complies with the lighting power budget requirements.

### APPROVED COMPUTER COMPLIANCE PROGRAMS

[www.energy.ca.gov/programs-and-topics/programs/building-energy-efficiency-standards/2019-building-energy-efficiency](http://www.energy.ca.gov/programs-and-topics/programs/building-energy-efficiency-standards/2019-building-energy-efficiency)

Projects utilizing the Performance Approach must use an Energy Commission-approved computer program. More information on "Approved Computer Compliance Programs" is available through the Energy Commission's website.



### ALTERNATIVE CALCULATION METHOD REFERENCE MANUAL FOR PERFORMANCE APPROACH

The Energy Commission provides an Alternative Calculation Method (ACM) Reference Manual that establishes the rules for the process of creating a building model, describes the proposed design definition, establishes the standard design and provides guidance on the Performance Compliance Certificate (PRF-01).

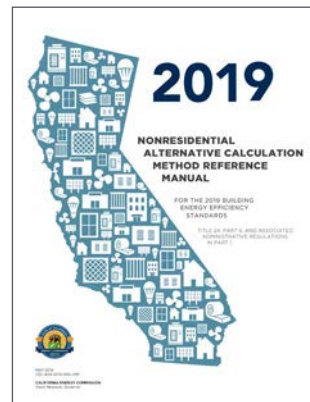

### CHECK YOUR UNDERSTANDING: PRESCRIPTIVE APPROACH IN PRACTICE

At the end of this section are exercises for lighting power adjustments, the Complete Building Method and the Area Category Method.



**NEW POWER ADJUSTMENT FACTORS IN 2019**

The Energy Code added three new Power Adjustment Factors related to daylighting design: clerestory fenestration, horizontal slats and light shelves.

The Complete Building Method is used when 90% of the building is the same space type. The Area Category Method is used for buildings with multiple space types; it can be used in combination with the Tailored Method. The Tailored Method is an option for areas that utilize lighting to highlight unique features, such as retail spaces, lobbies or waiting areas where awards or artwork are displayed.

**LIGHTING POWER ALLOWANCES**

The Energy Code regulates installed lighting power by space or building type. The lighting power allowances affect projects using any of the three compliance methods: Area Category, Complete Building or Tailored. The lighting power densities (LPD) used to calculate the lighting power allowance (LPA) for each space or building type are provided in the **Appendix** for each method.

For the Complete Building Method, the most significant LPD decreases in the 2019 Energy Code impacts the LPA of the following building types: religious facilities, assembly buildings, motion picture theaters and grocery stores.

For the Area Category Method, the most significant LPD decreases in the 2019 Energy Code impacts the LPA of the following function areas: museum displays, dining areas in cafeterias and fast food, videoconferencing studios, beauty salons and auditoriums.

**POWER ADJUSTMENT FACTORS**

Power adjustment factors (PAFs) provide flexibility when developing a lighting design, effectively allowing projects to reduce their reported lighting power use. PAFs incentivize the additional use of specific lighting controls and daylighting strategies.

During design, projects may receive credits toward the total installed power by installing certain types of lighting controls. These PAFs reflect control strategies that exceed requirements contained in the Energy Code. PAFs are available for:

**Lighting Power Density Updates from 2016 to 2019 for the Complete Building Method**

Type of Building	Lighting Power Density (W/ft <sup>2</sup> )		Type of Building	Lighting Power Density (W/ft <sup>2</sup> )	
	2019	Δ		2019	Δ
Assembly <sup>1</sup>	0.7	↓ 0.7	Religious	0.7	↓ 0.8
Financial Institution	0.65	↓ 0.35	Restaurant	0.7	↓ 0.4
Industrial/Manufacturing	0.6	↓ 0.4	Retail Store	0.9	New
Grocery Store	0.95	↓ 0.55	School	0.65	↓ 0.3
Gymnasium	0.65	New	Sports Arena	0.75	New
Library	0.7	↓ 0.5	Motion Picture Theater <sup>2</sup>	0.7	↓ 0.6
Healthcare	0.9	New	Performing Arts Theater <sup>2</sup>	0.8	↓ 0.5
Office	0.65	↓ 0.15	All Other Buildings	0.4	↓ 0.1
Parking Garage	0.13	↓ 0.07			

<sup>1</sup> Previously "Auditorium" building type under 2016 Energy Code.

<sup>2</sup> Previously "Theater" building type under 2016 Energy Code.

Based on Table 140.6-B in the Energy Code

- Demand responsive controls installed in buildings 10,000 ft<sup>2</sup> or smaller
- Institutional tuning controls
- Occupant sensing controls in large open plan offices
- Daylight dimming plus OFF control
- Clerestory fenestration
- Horizontal slats
- Light shelves

PAFs are provided in **Table 140.6-A** and includes the type of control, type of area it applies and the factor that can be used if the PAF is included in the project. Complete information on lighting power allowances and power adjustment factors for indoor spaces can be found in **Section 140.6**.

**OTHER LIGHTING POWER EXCLUSIONS**

The power used by certain lighting applications may be excluded from indoor lighting power calculations. The list of exclusions, per **Section 140.6(a)3**, is as follows:

- In theme parks: Lighting for themes and special effects.
- Studio lighting for film or photography, provided that these lighting systems are in addition to and separately switched from a general lighting system.
- Lighting for dance floors, lighting for theatrical and other live performances and theatrical lighting used for religious worship, provided that these lighting systems are additions to a general lighting system and are separately



PHOTO: K. PAPAMICHAEL

Clerestory Fenestration



Horizontal Slats



PHOTO: TUBELITE

Light Shelf

**Table 140.6-A: Lighting Power Adjustment Factors (PAF)**

Type of Control	Type of Area	Factor
<p>a. To qualify for any of the Power Adjustment Factors in this table, the installation shall comply with the applicable requirements in Section 140.6(a)2.</p> <p>b. Only one PAF may be used for each qualifying luminaire unless stated below.</p> <p>c. Lighting controls that are required for compliance with Part 6 shall not be eligible for a PAF.</p>		
<b>Daylighting Dimming plus OFF Control</b>	Luminaires in skylit daylit zone or primary sidelit daylit zone.	0.10
<b>Occupant Sensing Controls in Large Open Plan Offices</b>	In open plan offices > 250 ft <sup>2</sup> , one sensor controlling an area that is:	No larger than 125 ft <sup>2</sup>
		From 126 to 250 ft <sup>2</sup>
		From 251 to 500 ft <sup>2</sup>
<b>Institutional Tuning</b>	Luminaires in non-daylit areas. Luminaires that qualify for other PAFs in this table may also qualify for this tuning PAF.	0.10
	Luminaires in daylit areas. Luminaires that qualify for other PAFs in this table may also qualify for this tuning PAF.	0.05
<b>Demand Responsive Control</b>	All building types of 10,000 ft <sup>2</sup> or smaller. Luminaires that qualify for other PAFs in this table may also qualify for this PAF.	0.05
<b>Clerestory Fenestration*</b>	Luminaires in daylit areas adjacent to the clerestory. Luminaires that qualify for daylight dimming plus OFF control may also qualify for this PAF.	0.05
<b>Horizontal Slats*</b>	Luminaires in daylit areas adjacent to vertical fenestration with interior or exterior horizontal slats. Luminaires that qualify for daylight dimming plus OFF control may also qualify for this PAF.	0.05
<b>Light Shelves*</b>	Luminaires in daylit areas adjacent to clerestory fenestration with interior or exterior light shelves. This PAF may be combined with the PAF for clerestory fenestration. Luminaires that qualify for daylight dimming plus OFF control may also qualify for this PAF.	0.10

\* New for 2019

Based on Table 140.6-A in the Energy Code



controlled by a multiscene or theatrical cross-fade control station accessible only to authorized operators.

- Lighting intended for makeup, hair and costume preparation in performing arts facility dressing rooms, provided that the lighting is separately switched from the general lighting system, switched independently at each dressing station and is controlled with a vacancy sensor.
- In civic facilities, transportation facilities, convention centers and hotel function areas: Lighting for temporary exhibits, if the lighting is in addition to a general lighting system and is separately controlled from a panel accessible only to authorized operators.
- Lighting installed by the manufacturer in walk-in coolers or freezers, vending machines, food preparation equipment and scientific and industrial equipment.
- In office buildings with medical and clinical areas, healthcare facilities and medical and clinic buildings: Examination and surgical lights, low-ambient night-lights and lighting integral to medical equipment, provided that these lighting systems are additions to and separately switched from a general lighting system.
- Lighting for plant growth or maintenance, if it is controlled by a multi-level astronomical time-switch control that complies with the applicable provisions of **Section 110.9**.
- Lighting equipment that is for sale.
- Lighting demonstration equipment in lighting education facilities.
- Lighting that is required for exit signs subject to the CBC. Exit signs shall meet the requirements of the Appliance Efficiency Regulations.
- Exit way or egress illumination that is normally OFF and that is subject to the CBC.
- In hotel and motel buildings: Lighting in guest rooms (lighting in hotel and motel guest rooms shall comply with **Section 130.0(b)**). Indoor lighting not in guest rooms shall comply with all applicable nonresidential lighting requirements in the Energy Code.
- In high-rise residential buildings: Lighting in dwelling units (lighting in high-rise residential dwelling units shall comply with **Section 130.0(b)**). Indoor lighting not in dwelling units shall comply with all applicable nonresidential lighting requirements in the Energy Code.
- Temporary lighting systems, as defined in **Section 100.1**.
- Lighting in occupancy group U buildings less than 1,000 ft<sup>2</sup>.
- Lighting in unconditioned agricultural buildings less than 2,500 ft<sup>2</sup>.
- Lighting systems in qualified historic buildings, as defined in the California Historical Building Code (Title 24, Part 8), are exempt from the Lighting Power Density allowances if they consist solely of historic lighting components or replicas of historic lighting components. If lighting systems in qualified buildings contain some historic lighting components or replicas of historic components, combined with other lighting components, only those historic or historic replica components are exempt. All other lighting systems in qualified historic buildings shall comply with the lighting power density allowances.
- Lighting in nonresidential parking garages for seven or less vehicles: Lighting in nonresidential parking garages for seven or less vehicles shall comply with

the applicable residential parking garage provisions of **Section 150.0(k)**.

- Lighting for signs shall comply with **Section 140.8**.
- Lighting in refrigerated cases less than 3,000 ft<sup>2</sup>. (Lighting in refrigerated cases less than 3,000 ft<sup>2</sup> shall comply with the Appliance Efficiency Regulations.)
- Lighting in elevators where the lighting meets the requirements in **Section 120.6(f)**.
- Lighting connected to a Life Safety Branch or Critical Branch, as specified in **Section 517 of the California Electrical Code**.

## LUMINAIRE CLASSIFICATION AND POWER ADJUSTMENT

For modular lighting systems, such as track lighting, that allow the addition or relocation of luminaires without altering the wiring of the system, the wattage can be determined three ways, depending on the devices in the system:

1. The wattage is the greater of either:
  1. 30 watts per linear foot of track or plug-in busway
  2. The rated wattage of all of the luminaires included in the system, where the luminaire wattage is determined as specified in **Section 130.0(c)1**
2. For line-voltage lighting track and plug-in busway served by a track lighting integral current limiter or a dedicated track lighting supplementary overcurrent protection panel, the wattage can be determined two ways:
  1. The volt-ampere rating of current limiter as specified by **UL 1077**
  2. The sum of the ampere (A) rating of all of the current protection devices times the branch circuit voltages for track lighting supplementary overcurrent protection panel
3. For other modular lighting systems with power supplied by a driver, power supply or transformer, including but not limited to low-voltage lighting systems, the wattage of the system is the maximum rated input wattage of the driver, power supply or transformer published in the manufacturer's catalogs, as specified by **UL 2108 or 8750**.

In the Energy Code, luminaire classification and power adjustments have been added for small aperture tunable-white and dim-to-warm luminaires.

For qualifying small aperture tunable-white and dim-to-warm LED luminaires, the adjusted indoor lighting power of these luminaires shall be calculated by multiplying their maximum rated wattage by 0.75. This means that there is a 25% power adjustment reduction when qualifying luminaires are selected for your project.

Additionally, there are new requirements for the Tailored Method display lighting mounting height lighting power adjustment. For wall or floor display luminaires where the bottom of luminaires are at least 10 feet and 7 inches above the finished floor, the adjusted indoor lighting power is calculated by multiplying the maximum rated wattage and the mounting height adjustment factor from **Table 140.6-E**.

### DEFINITIONS: LUMINAIRE CLASSIFICATION AND POWER ADJUSTMENT

**Small aperture:** Qualifying luminaires longer than 18 inches shall be no wider than four inches. Qualifying luminaires with a length of 18 inches or less shall be no wider than eight inches.

**Color changing:** Qualifying tunable-white luminaires shall be capable of a color change greater than or equal to 2,000 Kelvin in correlated color temperature (CCT). Qualifying dim-to-warm luminaires shall be capable of color change greater than or equal to 500 Kelvin CCT.

**Controls:** Qualifying luminaires shall be connected to controls that allow color changing of the luminaires.

### EXCEPTION TO SECTION 130.0(C)6:

For Power-over-Ethernet lighting systems, power provided to installed non-lighting devices may be subtracted from the total power rating of the Power-over-Ethernet system.



### Section 140.6(c)1

## DETERMINING ALLOWED POWER UNDER THE COMPLETE BUILDING METHOD

The Complete Building Method may be used only on projects involving buildings with one primary type of use or in mixed-use buildings and tenant spaces where 90% of the leased space has one primary use. This is the simplest way to determine if the lighting plan complies with the Energy Code.

This method provides a single lighting power allowance for each building type listed in **Table 140.6-B** (provided in the **Appendix** of this guide). The lighting power allowance is calculated by multiplying the complete building area (ft<sup>2</sup>) by the allowed lighting power density (watt/ft<sup>2</sup>) for that building type.

$$\text{Allowed Lighting Power} = (\text{W/ft}^2 \text{ from Table 140.6-B}) \times (\text{floor area})$$

When applying the Complete Building Method on a project where a parking garage is included, the parking structure and building(s) should be calculated separately using the appropriate use type for each. This means that you can calculate and submit the compliance forms for the two spaces separately using the Complete Building Method.

### Section 140.6(c)2

## DETERMINING ALLOWED POWER UNDER THE AREA CATEGORY METHOD

The Area Category Method provides a single lighting power allowance for each primary function area listed in **Table 140.6-C** (provided in the **Appendix** of this guide). This exact value is calculated by multiplying the entire area (ft<sup>2</sup>) of each functional area (including floor space used by partitions) by the allowed lighting power density (watt/ft<sup>2</sup>) for that functional area. The total allowed lighting power is the sum of the lighting power allotments for all the areas covered by the permit application.

$$\text{Allowed Lighting Power} = \sum [(\text{W/ft}^2 \text{ from Table 140.6-C}) \times (\text{Primary Function floor area})]$$

### ADDITIONAL LIGHTING POWER ALLOTMENTS

Additional lighting energy use is allowed for some areas under the Area Category Method including, but are not limited to:

- Adjustable or directional accent, display and feature lighting
- Decorative lighting
- Ornamental lighting
- Task lighting





### Section 140.6(c)3

## DETERMINING ALLOWED POWER UNDER THE TAILORED METHOD

The Tailored Method is typically used for projects that include space types listed in **Table 140.6-D** (provided in the **Appendix** of this guide) of the Energy Code. Within nonresidential applications, these space types include:

- Auditorium areas
- Dining areas
- Hotel areas
- Main entry lobby
- Retail sales
- Religious worship areas
- Theater areas
- Exhibit and museum areas
- Convention, conference, multipurpose and meeting center areas

### GENERAL LIGHTING POWER ALLOTMENTS

Under the Tailored Method, general lighting power allotments are tailored to each space or area based on the dimensions of the space, including luminaire mounting height and **Table 140.6-D** illumination levels. The process includes the following steps:

1. Determine the primary function area and the illuminance value (listed in lux) per **Table 140.6-D**
2. Determine the room cavity ratio (RCR) according to **Table 140.6-F**
3. Use the illuminance value and the RCR to find the allowed LPD according to **Table 140.6-G**

Areas with high ceilings have a high RCR, making them more difficult to light. The Tailored Method allows greater LPD allowances as the RCR increases. The RCR trigger points for increased LPD allowances start at 2.0, then increase at 3.5 and 7.0.

### GENERAL LIGHTING TRADE-OFFS

The Tailored Method allows for certain LPD trade-offs for general lighting only. Trade-offs must be documented using compliance forms and must be kept within conditioned areas or within unconditioned areas. Trade-offs are allowed:

- From one conditioned area using the Tailored Method to another conditioned area using either the Tailored or Area Category Method
- From one unconditioned area using the Tailored Method to another unconditioned area using either the Tailored or Area Category Method



### ADDITIONAL LIGHTING POWER ALLOTMENTS

In addition to general lighting power allotments, the Tailored Method provides lighting power allotments for special tasks that use lighting as a way to draw attention to an area by providing visual contrast to what is contributed from the general lighting. The following is a sample selection of lighting power allotments in the Energy Code. The complete list can be found in **Section 140.6(c)3**:

- **Wall display lighting:** Supplementary lighting required to highlight features such as artwork or awards displayed on perimeter walls. It provides a higher level of illuminance to a specific area than the level of surrounding ambient illuminance.
- **Ornamental or special effects lighting:** Decorative indoor luminaires are typically chandeliers, sconces, theatrical projectors, dynamic or moving lighting or illuminated colored panels that are not providing general illumination.

**EXCEPTION: ROOM CAVITY RATIO**

*RCR allows for imaginary or virtual walls when the boundaries are established by “high stack” elements (close to the ceiling structure and high storage, such as shelves) or high partial walls defined as “permanent full height interior partitions” described in Section 140.6(c)3Giii.*

**IN-PERSON ENERGY STANDARDS TRAINING**

*Energy Code Ace offers training events at the investor-owned utility energy education training centers and other locations throughout California.*

*Have a group of 20 or more attendees that need more help to apply the Energy Code in practice? Training sessions can also be requested and scheduled to fulfill needs not covered by the scheduled sessions.*

*Submit a request at [energycodeace.com/content/training-request](http://energycodeace.com/content/training-request).*

### ROOM CAVITY RATIO

The room cavity ratio (RCR) describes the configuration of a room. Rooms with high ceilings are typically more difficult to illuminate and have a high RCR. Because luminaires are not as effective in areas with a high RCR, the Energy Code allows a higher lighting power density.

The RCR must be calculated for any function area using the Tailored Method. **Table 140.6-F** provides the equations for the calculations. The RCR is based on the entire space bounded by floor-to-ceiling partitions. If a task area with a larger space is not bounded by floor-to-ceiling partitions, the RCR of the entire space must be used for the task area.

**Table 140.6-F: Room Cavity Ratio (RCR) Equations**

Determine the room cavity ratio for Table 140.6-G using one of the following equations	
Room cavity ratio for rectangular rooms:	Room cavity ratio for irregularly shaped rooms:
$RCR = \frac{5 \times H \times (L + W)}{L \times W}$	$RCR = \frac{2.5 \times H \times P}{A}$

*H = Vertical distance from the work plane to the center line of the lighting fixture  
L = Length      W = Width      P = Perimeter      A = Area of the room*

# EXAMPLE EXERCISE: CALCULATE ACTUAL AND ALLOWED LIGHTING POWER

## J.S.H. ASSOCIATES 1,944 FT<sup>2</sup> OFFICE BUILDING

The following example shows the steps to determine whether the office lighting design complies with Mandatory requirements and the Prescriptive requirements. The floor plan below shows both the lighting controls and luminaires specified for the office. Steps to show compliance with Mandatory control requirements are included in this section, as well as the following steps to show compliance with Prescriptive requirements.

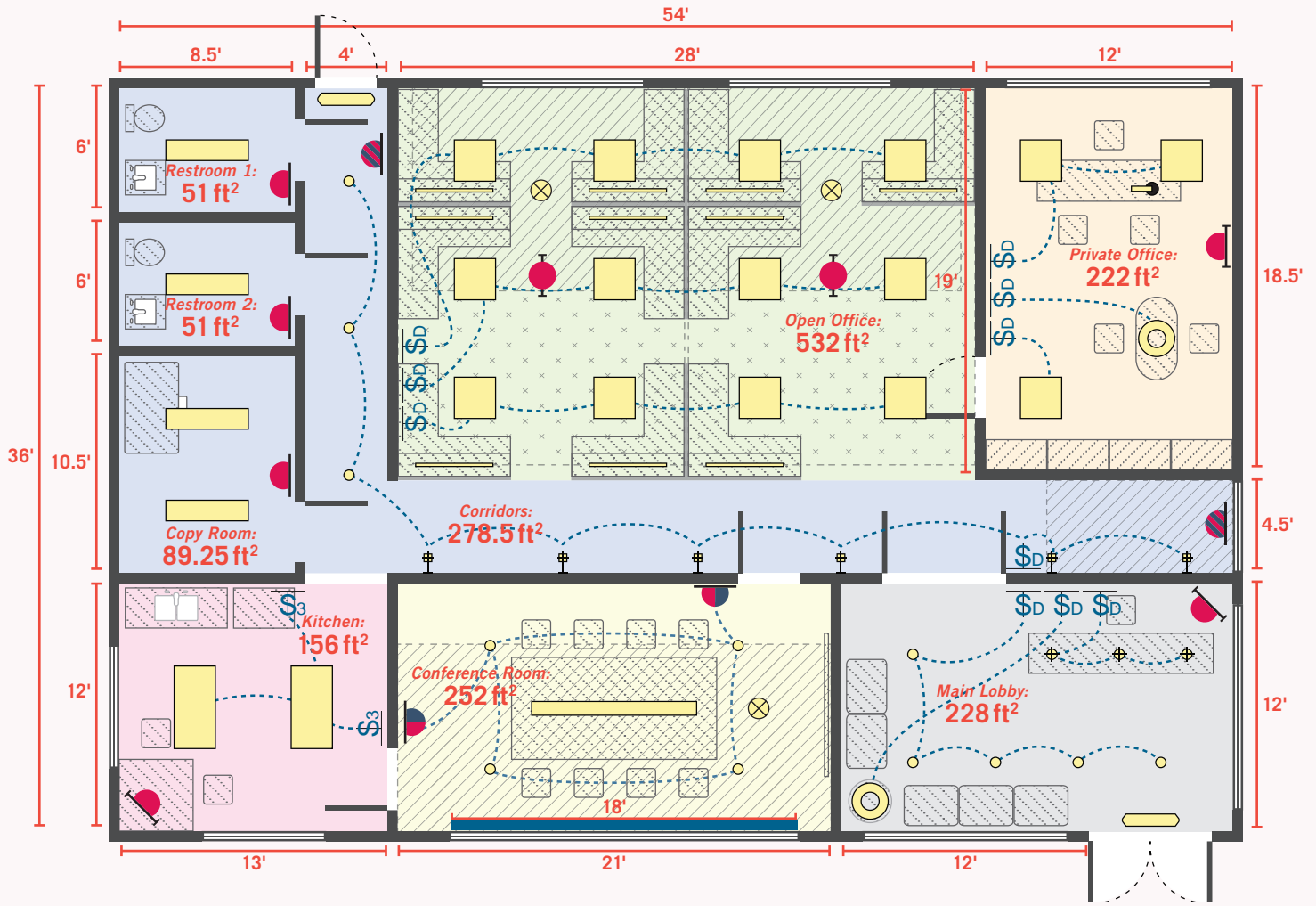









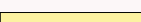

- Occupancy control with manual ON/OFF switch
- Combined manual dimming plus partial-ON occupant sensing control for the downlights and pendant
- Partial-ON occupancy sensor
- Partial-OFF occupancy control
- 360-degree View Occupancy Sensor (covering 251 to 500 ft<sup>2</sup> for PAF of 0.2)

- Daylighting sensor
- Light shelf
- Primary Sidelit Daylit Zone
- Secondary Sidelit Daylit Zone
- Switch with dimming and manual ON/OFF
- Three-way dimming switch

Ceiling height: 12'  
 Whiteboard (in Conference Room) length: 7'  
 Window height: 6'  
 Scale: 1/8" = 1'

## LIGHTING SCHEDULE

Name	Symbol	Luminaire	Quantity	System Wattage	Total Watts	Efficacy (lm/W)
1		<b>2 x 2 LED RECESSED TROFFER</b> Cree CR22	15	35	525	90–100
2		<b>1 x 4 1-LAMP FLUORESCENT RECESSED TROFFER</b> Finelite HPR with Sylvania 32W T8 lamp; Sylvania Quicktronic Ballast	4	28	112	89
3		<b>2 x 4 2-LAMP FLUORESCENT RECESSED TROFFER</b> Finelite HPR with Sylvania 32W T8 lamp; Sylvania Quicktronic Ballast	2	54	108	89
4		<b>8' LED SUSPENDED LUMINAIRE</b> Visa Linessé	1	85	85	84
5		<b>6" LED RECESSED DOWNLIGHT</b> Cree CR6	12	12	144	90
6		<b>LED WALL SCONCE</b> Tech Lighting Mura	6	8	48	50
7		<b>LED PENDANT</b> Philips Vetro	3	10	30	76
8		<b>LED SUSPENDED LUMINAIRE</b> Philips Ledino Cinta Suspension Light	2	22.5	45	100
11		<b>LED EXIT SIGN</b> Ciata Lighting Exit Sign and Emergency Lights	2	2	Exempt per §140.6(a)3	100
<b>TOTAL INSTALLED LIGHTING WATTS:</b>					<b>1,097 W</b>	
<b>PORTABLE LIGHTING</b>						
9		<b>45" LED UNDERCABINET TASK LIGHTING</b> Finelite Edge Undercabinet	10	12.2	122	62.2
10		<b>LED TASK LIGHT</b> Koncept Z Bar Mini Task Light	1	6.5	6.5	—
<b>TOTAL PORTABLE LIGHTING WATTS</b>					<b>128.5 W</b>	
<b>DAYLIGHTING DEVICES</b>						
N/A		<b>LIGHT SHELF</b> Architectural Grilles & Sunshades (AGS)	1	—	—	—
<b>TOTAL WATTS:</b>					<b>1,225.5 W</b>	

# DETERMINING COMPLIANCE WITH MANDATORY REQUIREMENTS

The lighting control plan is compliant if the controls fulfill all Mandatory requirements per **Section 130.1**. These requirements are discussed in depth starting on **page 37** of this guide.

This section shows how to document and verify the compliance of the proposed controls in Section H: Indoor Lighting Controls (Not Including PAFs), of form NRCC-LTI-E.

**NRCC-LTI-E, SECTION H. INDOOR LIGHTING CONTROLS (NOT INCLUDING PAFs)**  
 Complete all columns in the table in Section H of Form NRCC-LTI-E to compute whether or not the controls in the space are compliant.

**H. INDOOR LIGHTING CONTROLS (Not Including PAFs)**

Table Instructions: Please include lighting controls for conditioned and unconditioned spaces in this table. When an option having a \* is selected, the notes section of this table must be completed. The lighting controls section of the Compliance Summary Table on the first page will show "DOES NOT COMPLY" if the notes are left blank.

Building Level Controls											
01				02				03			
Mandatory Demand Response §110.12(c)				Shut-Off Controls §130.1(c)				Field Inspector			
Not Required ≤ 10,000 SF				See Area/Space Level Controls				Pass		Fail	
Area Level Controls											
04	05	06	07	08	09	10	11	12			
Area Description	Complete Building or Area Category Primary Function Area	Area Controls §130.1(a)	Multi-Level Controls §130.1(b)	Shut-Off Controls §130.1(c)	Primary/Skylit Daylighting §130.1(d)	Secondary Daylighting §140.6(d)	Interlocked Systems §140.6(a)1	Field Inspector			
								Pass		Fail	
Open Plan Office	Office (open)	Manual ON/OFF	Dimmer	Occ. Sensor	Included	Included	<input type="checkbox"/>	<input type="checkbox"/>		<input type="checkbox"/>	
Private Office	Office (≤ 250 square feet)	Manual ON/OFF	Dimmer	Partial On*	NA	Included	<input type="checkbox"/>	<input type="checkbox"/>		<input type="checkbox"/>	
Conference Room	Convention, Conference, Multipurpose, and Meeting Center	Manual ON/OFF	Dimmer	Occ. Sensor	Included	Exempt*	<input type="checkbox"/>	<input type="checkbox"/>		<input type="checkbox"/>	
Main Lobby	Main Entry Lobby	Manual ON/OFF	Dimmer	Occ. Sensor	Exempt*	Exempt*	<input type="checkbox"/>	<input type="checkbox"/>		<input type="checkbox"/>	
Kitchen	Kitchen, Food Preparation	Manual ON/OFF	Dimmer	Occ. Sensor	Exempt*	Exempt*	<input type="checkbox"/>	<input type="checkbox"/>		<input type="checkbox"/>	
Corridors	Corridor	Manual ON/OFF	Dimmer	Partial Off*	Exempt*	Exempt*	<input type="checkbox"/>	<input type="checkbox"/>		<input type="checkbox"/>	
Restroom #1	Restroom	Manual ON/OFF	Exempt*	Occ. Sensor	NA	NA	<input type="checkbox"/>	<input type="checkbox"/>		<input type="checkbox"/>	
Restroom #2	Restroom	Manual ON/OFF	Exempt*	Occ. Sensor	NA	NA	<input type="checkbox"/>	<input type="checkbox"/>		<input type="checkbox"/>	
Copy Room	Copy Room	Manual ON/OFF	Exempt*	Occ. Sensor	NA	NA	<input type="checkbox"/>	<input type="checkbox"/>		<input type="checkbox"/>	
*NOTES: Controls with a * require a note in the space below explaining how compliance is achieved. EX: Conference 1: Primary/Skylight Daylighting: Exempt because less than 120 watts of general lighting; EXCEPTION 1 to §130.1(d)2							13				
							Plan Sheet Showing Daylit Zones:				
Private Office	Partial-on occupancy sensor is used since space is a private office less than 250 SF that requires multi-level controls										
Conference Room	There is less than 120 W of general lighting power in the secondary daylight zone										
Main Lobby	There is less than 120 W of general lighting power in the primary and secondary daylight zones.										
Kitchen	There is less than 120 W of general lighting power in the primary and secondary daylight zones.										
Corridors	Corridors are a secondary space that must use partial-OFF shut-off controls. Exempt from daylighting requirements because there is less than 120 W of general electric lighting in the primary daylight zone.										
Restroom #1	Restrooms are exempt from multi-level controls.										
Restroom #2	Restrooms are exempt from multi-level controls.										
Copy Room	Less than 100 SF, exempt from multi-level controls.										

# DETERMINING COMPLIANCE WITH THE PRESCRIPTIVE REQUIREMENTS

The lighting plan complies if the total adjusted installed lighting power is less than or equal to the allowed lighting power. Steps to show compliance with the Prescriptive requirements include:

1. Calculate the lighting power allowance.
2. Calculate the total installed lighting power for all planned and portable lighting from a lighting schedule.
3. Apply power adjustment factors (PAFs) earned by specifying lighting controls that go beyond the Energy Code requirements.
4. Determine the adjusted lighting power using answers from steps one through three.
5. Compare the adjusted installed lighting power to the allowed lighting power.

**LUMINAIRE CLASSIFICATION BY RATED POWER**  
Section 130.0(c)

The Energy Code considers the maximum rated power of a luminaire instead of the amount of energy used by a lamp inside of that luminaire.

For example, a luminaire that can accommodate a 100W incandescent lamp is considered a 100W luminaire for compliance purposes, even if it uses a 20W LED lamp.

This section includes an example calculation of allowed lighting power using the Area Category Method and the Complete Building Method. The example offers notes on what sections of the Certificates of Compliance for Nonresidential Indoor Lighting are necessary to support the compliance process for this scenario.



## AREA CATEGORY METHOD

This section of the example uses the Area Category Method to determine allowed lighting power. Area by area, the lighting power of the spaces within the building is calculated separately for conditioned and unconditioned space types. All conditioned areas in the project are added together and all unconditioned areas in the project are added together. If the total lighting power is greater than what the Energy Code allows, the lighting design does not comply using the Area Category Method and it will have to be revised to achieve a lower lighting power. Alternatively, the design can be evaluated using the Tailored Method of compliance to see if it complies. Section C: Compliance Results of form NRCC-LTI-E, shown below, will be completed at the end of this example.

**NRCC-LTI-E, SECTION C. COMPLIANCE RESULTS**

Section C, "Compliance Results," in Form NRCC-LTI-E ultimately determines whether or not the space is compliant (Column 09).

C. COMPLIANCE RESULTS										
Table instructions: If any cell on this table says "DOES NOT COMPLY" or "COMPLIES with Exceptional Conditions" refer to Table D. for guidance.										
Lighting in conditioned and unconditioned spaces must not be combined for compliance per §140.6(b)1.	Allowed Lighting Power per §140.6(b) (Watts)					=	Adjusted Lighting Power per §140.6(a) (Watts)			Compliance Results
	01	02	03	04	05		06	07	08	
	Complete Building §140.6(c)1 (See Table I)	Area Category §140.6(c)2 (See Table I)	Area Category Additional §140.6(c)2G (+) (See Table J)	Tailored §140.6(c)3 (+) (See Table K)	Total Allowed (Watts)		Total Designed (Watts) (See Table F)	Adjustments PAF Control Credits §140.6(a)2 (-) (See Table P)	Total Adjusted (Watts) *Includes Adjustments	
Conditioned:						≥				
Unconditioned:						≥				
Controls Compliance (See Table H for Details)										
Rated Power Reduction Compliance (See Table Q for Details)										

05 Must be ≥ 08  
§140.6

## 1

**LIGHTING POWER ALLOWANCE**

1. There are eight primary function areas in this space. The lighting power density of each area, according to **Table 140.6-C**, is automatically inputted in the form depending on the primary function area selected.
2. Determine the size (ft<sup>2</sup>) of each area type from the inside of the wall.
3. The wattage allowance is calculated by multiplying the square footage of each area type by the allowed lighting power density.
4. Allowed watts are automatically totaled as areas are added.

NRCC-LTI-E, SECTION I. LIGHTING POWER ALLOWANCE FOR AREA CATEGORY METHODS							
Complete columns 1 through 4 in the table in Section I of Form NRCC-LTI-E to calculate total allowed wattage.							
I. LIGHTING POWER ALLOWANCE: COMPLETE BUILDING OR AREA CATEGORY METHODS							
Table Instructions: Complete the table for each area complying using the Complete Building or Area Category Methods per §140.6(b). Indicate if additional lighting power allowances per §140.6(c) or adjustments per §140.6(a) are being used.							
Conditioned Spaces							
01	02	03	04	05	06		
Area Description	Complete Building or Area Category Primary Function Area	Allowed Density (W/ft <sup>2</sup> )	Area (ft <sup>2</sup> )	Allowed Wattage (Watts)	Additional Allowances / Adjustment		
					Area Category	PAF	
Open Plan Office	Office (open)	0.6	532	319.2	<input checked="" type="checkbox"/>	<input checked="" type="checkbox"/>	
Private Office	Office (≤ 250 square feet)	0.7	222	155.4	<input checked="" type="checkbox"/>	<input type="checkbox"/>	
Conference Room	Convention, Conference, Multipurpose, and Meeting Center	0.85	252	214.2	<input type="checkbox"/>	<input checked="" type="checkbox"/>	
Main Lobby	Main Entry Lobby	0.85	228	193.8	<input checked="" type="checkbox"/>	<input type="checkbox"/>	
Kitchen	Kitchen, Food Preparation	0.95	156	148.2	<input type="checkbox"/>	<input type="checkbox"/>	
Corridors	Corridor	0.6	278.5	167.1	<input type="checkbox"/>	<input type="checkbox"/>	
Restroom #1	Restroom	0.65	51	33.15	<input type="checkbox"/>	<input type="checkbox"/>	
Restroom #2	Restroom	0.65	51	33.15	<input type="checkbox"/>	<input type="checkbox"/>	
Copy Room	Copy Room	0.5	89.25	44.63	<input type="checkbox"/>	<input type="checkbox"/>	
<b>TOTAL:</b>			<b>1,859.75</b>	<b>1,308.83</b>	See Tables J or P for detail		

**ADDITIONAL LIGHTING WATTAGE ALLOWANCE**

Some of the areas in the example are eligible for an additional wattage allowance for specialized lighting. The Additional Lighting Power column in **Table 140.6-C** is used to determine how much can be allocated. This is a “use it, or lose it” allowance; if there is no lighting in the schedule that qualifies for the additional allowance, it cannot be used.

The suspended luminaire in the lobby is classified as “Ornamental lighting,” as defined in **Section 100.1** and in accordance with **Section 140.6(c)2**. Additionally, the office spaces qualify for the portable office lighting wattage allowance.

1. Determine the applicable qualifying lighting system from **Table 140.6-C**.
2. Determine the lighting area, length or number of ATMs and mirrors.
3. The additional wattage allowance is automatically calculated by multiplying the area, length, or number determined in Step 2 by the additional wattage per allowance. Compare to the specified fixture for both scenarios.
4. The smaller of either the newly calculated allowed watts or the total design watts of the luminaire is chosen automatically.

In this example, there are 22.5 watts for ornamental lighting, 6.5 watts for portable office lighting in the private office, and 106.4 watts for portable office lighting in the open plan office, totaling 135.4 watts of additional allowed lighting wattage.

**ORNAMENTAL OR TASK LIGHTING REQUIREMENTS**

Other lighting, such as ornamental or task, must be switched separately from general lighting and is not required to be paired with multilevel, daylighting or demand response controls.

### TOTAL LIGHTING POWER ALLOWANCES

The total lighting power allowance is calculated by adding the additional lighting wattage allowance to the general lighting power allowance.

$$1,308.8W + 135.4W = 1,444.2W$$

**NRCC-LTI-E, SECTION J. ADDITIONAL LIGHTING ALLOWANCE: AREA CATEGORY METHOD QUALIFYING LIGHTING SYSTEM**

Complete all columns in the table in Section J of Form NRCC-LTI-E to calculate additional lighting allowances that can be factored into the Area Method calculation.

**J. ADDITIONAL LIGHTING ALLOWANCE: AREA CATEGORY METHOD QUALIFYING LIGHTING SYSTEM**

Table Instructions: Please complete the table for all areas indicated in Table I as using an additional allowance per the Area Category Method in Table 140.6-C.

Conditioned Spaces									
01	02	03	04	05	06	07	08	09	10
Area Description	Primary Function Area	Applicable Qualifying Lighting System from Table 140.6-C	Allowed Density (W/ft <sup>2</sup> ) or (W/lf)	Ltg Area, Length or ATM/Mirror (ft <sup>2</sup> , lf or #)	Extra Allowance (Watts)	Luminaire Name or Item Tag	Watts per Luminaire	Number of Luminaires	Total Design Watts
Main Lobby	Main Entry Lobby	Ornamental	0.3	228	68.4	8	22.5	1	22.5
						Add Luminaire	Remove Last		
Total Design Watts:	Calculated Allowance (Watts):	Total Additional Allowance for this area:		Add System					
22.5	68.4	22.5							
Private Office	Office (≤ 250 square feet)	Portable Office	0.2	222	44.4	10	6.5	1	6.5
						Add Luminaire	Remove Last		
Total Design Watts:	Calculated Allowance (Watts):	Total Additional Allowance for this area:		Add System					
6.5	44.4	6.5							
Open Plan Office	Office (open)	Portable Office	0.2	532	106.4	9	12.2	10	122
						Add Luminaire	Remove Last		
Total Design Watts:	Calculated Allowance (Watts):	Total Additional Allowance for this area:		Add System					
122	106.4	106.4							
		11							
<b>Total Additional Allowance (Watts) CONDITIONED SPACES:</b>		<b>135.4</b>							

## 2 INSTALLED LIGHTING POWER

The installed lighting power includes all planned permanent and portable lighting. Complete the lighting schedule in Section F: Indoor Lighting Fixture Schedule of Form NRCC-LTI-E to determine the total to use for compliance purposes.

**NRCC-LTI-E, SECTION F. INDOOR LIGHTING FIXTURE SCHEDULE**

The schedule is used to fill in Section F, "Indoor Lighting Fixture Schedule", in Form NRCC-LTI-E.

**F. INDOOR LIGHTING FIXTURE SCHEDULE**

Table Instructions: Include all permanent designed lighting and all portable lighting in offices.

Designed Wattage: Conditioned Spaces										
01	02	03	04	05	06	07	08	09	10	
Name or Item Tag	Complete Luminaire Description	Modular (Track) Fixture	Small Aperture & Color Change <sup>1</sup>	Watts per luminaire <sup>2</sup>	How Wattage is determined	Total number luminaires	Exempt per §140.6(a)3	Design Watts	Field Inspector	
									Pass	Fail
1	2 x 2 LED Recessed Troffer	<input type="checkbox"/>	<input type="checkbox"/>	35	Mfr. Spec <sup>2</sup>	15	<input type="checkbox"/>	525	<input type="checkbox"/>	<input type="checkbox"/>
2	1 x 4 Fluorescent Recessed Troffer	<input type="checkbox"/>	<input type="checkbox"/>	28	NA8 Default	4	<input type="checkbox"/>	112	<input type="checkbox"/>	<input type="checkbox"/>
3	2 x 4 Fluorescent Recessed Troffer	<input type="checkbox"/>	<input type="checkbox"/>	54	NA8 Default	2	<input type="checkbox"/>	108	<input type="checkbox"/>	<input type="checkbox"/>
4	8' LED Suspended Luminaire	<input type="checkbox"/>	<input type="checkbox"/>	85	Mfr. Spec <sup>2</sup>	1	<input type="checkbox"/>	85	<input type="checkbox"/>	<input type="checkbox"/>
5	6" LED Recessed Downlight	<input type="checkbox"/>	<input type="checkbox"/>	12	Mfr. Spec <sup>2</sup>	12	<input type="checkbox"/>	144	<input type="checkbox"/>	<input type="checkbox"/>
6	LED Wall Sconce	<input type="checkbox"/>	<input type="checkbox"/>	8	Mfr. Spec <sup>2</sup>	6	<input type="checkbox"/>	48	<input type="checkbox"/>	<input type="checkbox"/>
7	LED Pendant	<input type="checkbox"/>	<input type="checkbox"/>	10	Mfr. Spec <sup>2</sup>	3	<input type="checkbox"/>	30	<input type="checkbox"/>	<input type="checkbox"/>
8	LED Suspended Luminaire	<input type="checkbox"/>	<input type="checkbox"/>	22.5	Mfr. Spec <sup>2</sup>	2	<input type="checkbox"/>	45	<input type="checkbox"/>	<input type="checkbox"/>
9	45" LED Undercabinet Task Lighting	<input type="checkbox"/>	<input type="checkbox"/>	12.2	Mfr. Spec <sup>2</sup>	10	<input type="checkbox"/>	122	<input type="checkbox"/>	<input type="checkbox"/>
10	LED Task Light	<input type="checkbox"/>	<input type="checkbox"/>	6.5	Mfr. Spec <sup>2</sup>	1	<input type="checkbox"/>	6.5	<input type="checkbox"/>	<input type="checkbox"/>
11	LED Exit Sign	<input type="checkbox"/>	<input type="checkbox"/>	2	Mfr. Spec <sup>2</sup>	2	<input checked="" type="checkbox"/>		<input type="checkbox"/>	<input type="checkbox"/>
<b>Total Designed Watts CONDITIONED SPACES:</b>								<b>1,225.5</b>		



### 3 POWER ADJUSTMENT FACTORS

The lighting plan must be evaluated for potential lighting power adjustment factors (PAFs) that can be used in your calculations.

Lighting control requirements that are Mandatory (**Section 130.1**) do not qualify, only lighting PAFs listed in **Table 140.6-A**. This lighting design is eligible for the occupant sensing control in large open plan offices PAF, as well as the light shelf PAF (luminaires in daylit areas adjacent to clerestory fenestration with interior or exterior light shelves) that was added in the 2019 Energy Code. The light shelf PAF may be combined with the PAF for clerestory fenestration. Luminaires that qualify for daylight dimming plus OFF control may also qualify for this PAF.

To calculate the occupant sensing control in large open plan offices PAF, the factor of 0.2 is multiplied by the total wattage of the general luminaires installed in the large open plan office (420W, from the 12 LED recessed troffers).

$$420W \times 0.20 = 84W$$

To calculate the light shelf PAF, the installed lighting power in the daylit area adjacent to the clerestory fenestration with light shelves is multiplied by the PAF factor. In our example, the light shelf is in the conference room. The daylit zone is determined to encompass the whole conference room, which has one 8' pendant that is 85W and four downlights that are 12W each.

$$133W \times 0.10 = 13.3W$$

For this example, the total power adjustment is 121.7W.

$$84W + 13.3W = 97.3W$$

**NRCC-LTI-E, SECTION P. POWER ADJUSTMENT: LIGHTING CONTROL CREDIT [POWER ADJUSTMENT FACTOR (PAF)]**  
 Complete the table in Section P of Form NRCC-LTI-E to calculate lighting control credits that can be used as a power adjustment factor in your calculations.

P. POWER ADJUSTMENT: LIGHTING CONTROL CREDIT (POWER ADJUSTMENT FACTOR (PAF))															
Table Instructions: Please complete the table for all areas indicated in Table I or Table K as using a PAF credit described in §140.6(a)2.															
Conditioned Spaces															
01	02										03	04	05	06	07
Area Description	PAF per §140.6(a)2 <sup>1</sup> (*Can be used in conjunction with other PAFs)										Luminaires Controlled for PAF Credit				Additional Control Credit Allowance (Watts)
	1	2A	2B	2C	3A*	3B*	4*	5*	6*	7*	Luminaire Name or Item Tag	Watts per Luminaire	Number of Luminaires	Lighting Controlled (Watts)	
	Pick up to one			Pick up to one			Pick up to one <sup>2</sup>								
Conference Room	<input type="checkbox"/>	<input type="checkbox"/>	<input type="checkbox"/>	<input type="checkbox"/>	<input type="checkbox"/>	<input type="checkbox"/>	<input type="checkbox"/>	<input type="checkbox"/>	<input type="checkbox"/>	<input checked="" type="checkbox"/>	4	85	1	85	8.5
	<input type="checkbox"/>	<input type="checkbox"/>	<input type="checkbox"/>	<input type="checkbox"/>	<input type="checkbox"/>	<input type="checkbox"/>	<input type="checkbox"/>	<input type="checkbox"/>	<input type="checkbox"/>	<input type="checkbox"/>	5	12	4	48	4.8
	<a href="#">Add Luminaire</a> <a href="#">Remove Last</a>														
Open Plan Office	<input type="checkbox"/>	<input type="checkbox"/>	<input type="checkbox"/>	<input checked="" type="checkbox"/>	<input type="checkbox"/>	<input type="checkbox"/>	<input type="checkbox"/>	<input type="checkbox"/>	<input type="checkbox"/>	<input type="checkbox"/>	1	35	12	420	84
	<a href="#">Add Luminaire</a> <a href="#">Remove Last</a>														
08										09					
<input checked="" type="checkbox"/>	All spaces applying PAF 5, 6, or 7 include a daylight design meeting requirements in §140.3(d). See Table S.										<b>Total Power Adjustment (Watts) CONDITIONED SPACES:</b>				97.3

<sup>1</sup> FOOTNOTES: PAFs outlined in Table 140.6-A include 1) Daylight dimming plus OFF; 2A) Occupant sensors in offices ≤ 125 ft<sup>2</sup>; 2B) Occupant sensors in offices from 126 - 250 ft<sup>2</sup>; 2C) Occupant sensors in offices from 251 - 500 ft<sup>2</sup>; 3A) Institutional tuning, non-daylit areas; 3B) Institutional tuning, daylit areas; 4) Demand response; 5) Clerestory fenestration; 6) Horizontal slats; 7) Light shelves.  
<sup>2</sup> Luminaires that qualify for PAF 5, 6, or 7 can be used in conjunction with PAF 1.

### 4 ADJUSTED LIGHTING POWER

Column 8 in the table in Section C of Form NRCC-LTI-E is automatically used to calculate the adjusted installed lighting power by subtracting the PAF from the total installed lighting.

$$1,225.5W - 97.3W = 1,128.2W \text{ of adjusted lighting power}$$

### 5 COMPLIANCE RESULTS

Column 9 of the table in Section C of Form NRCC-LTI-E determines if this lighting schedule is compliant. Column 5 must be greater than or equal to column 8 for the lighting design to be compliant.

For this example, **the lighting schedule is compliant.**

**NRCC-LTI-E, SECTION C. COMPLIANCE RESULTS**  
 Upon completing the sections appropriate for the lighting project, Section C should be automatically populated with the calculated figures and conditionals.

C. COMPLIANCE RESULTS													
Table Instructions: If any cell on this table says "DOES NOT COMPLY" or "COMPLIES with Exceptional Conditions" refer to Table D. for guidance.													
Lighting in conditioned and unconditioned spaces must not be combined for compliance per §140.6(b)1.	Allowed Lighting Power per §140.6(b) (Watts)				=	Total Allowed (Watts)	≥	Adjusted Lighting Power per §140.6(a) (Watts)		=	Total Adjusted (Watts) *Includes Adjustments	05 Must be ≥ 08 §140.6	
	01	02	03	04				06	07				08
	Complete Building §140.6(c)1 (See Table I)	Area Category §140.6(c)2 (See Table I)	Area Category Additional §140.6(c)2G (+) (See Table J)	Tailored §140.6(c)3 (+) (See Table K)				Total Designed (Watts) (See Table F)	Adjustments PAF Control Credits §140.6(a)2 (-) (See Table P)				
<b>Conditioned:</b>		1,308.83	135.4		=	<b>1,444.23</b>	≥	1,225.5	97.3	=	<b>1,128.2</b>	<b>COMPLIES</b>	
<b>Unconditioned:</b>					=		≥			=			
<b>Controls Compliance (See Table H for Details)</b>										<b>COMPLIES with Exceptional Conditions</b>			
<b>Rated Power Reduction Compliance (See Table Q for Details)</b>										<b>Not Applicable</b>			

## B COMPLETE BUILDING METHOD

The Complete Building Method can be used for any building type. To evaluate whether the project complies, calculate the allowed lighting power by multiplying square footage by one lighting power density for the whole project and compare it to the actual lighting power.

The Complete Building Method may be used only in projects involving entire buildings with one primary use or in mixed-use buildings and tenant spaces where 90% of the spaces have one primary use.

**ONLINE SELF-STUDY**  
[energycodeace.com/content/training-ace/training\\_event\\_type=course-type-self-study](https://energycodeace.com/content/training-ace/training_event_type=course-type-self-study)

Additional educational materials covering the Tailored Method are available via the online self-study materials from Energy Code Ace.

## 1 LIGHTING POWER ALLOWANCE

According to **Table 140.6-B**, this space is classified as an office building. Form NRCC-LTI-E takes the following steps to calculate allowed lighting power for the project:

1. Determine the allowed lighting power density of an office building according to **Table 140.6-B**.

Office Building: **0.65 W/ft<sup>2</sup>**

2. Multiply the allowed lighting power density by the area of the space.

**0.65 W/ft<sup>2</sup> x 1,944 ft<sup>2</sup> = 1,263.6W allowed lighting power under the Complete Building Method**

**NRCC-LTI-E, SECTION I. LIGHTING POWER ALLOWANCE FOR COMPLETE BUILDING METHODS**  
 Complete columns 1 through 4 in the table in Section I of Form NRCC-LTI-E to calculate total allowed wattage.

I. LIGHTING POWER ALLOWANCE: COMPLETE BUILDING OR AREA CATEGORY METHODS							
Table Instructions: Complete the table for each area complying using the Complete Building or Area Category Methods per §140.6(b). Indicate if additional lighting power allowances per §140.6(c) or adjustments per §140.6(a) are being used.							
Conditioned Spaces							
01	02		03	04	05	06	
Area Description	Complete Building or Area Category Primary Function Area		Allowed Density (W/ft <sup>2</sup> )	Area (ft <sup>2</sup> )	Allowed Wattage (Watts)	Additional Allowances / Adjustment	
	Area Category	PAF					
Office	Office Building		0.65	1,944	1,263.6	<input type="checkbox"/>	<input checked="" type="checkbox"/>
<b>TOTAL:</b>				<b>1,944</b>	<b>1,263.6</b>	See Tables J or P for detail	

## 2 DETERMINING COMPLIANCE UNDER THE COMPLETE BUILDING METHOD

Section C: Compliance Results in Form NRCC-LTI-E determines if this lighting schedule is compliant under the Complete Building Method.

**NRCC-LTI-E, SECTION C. COMPLIANCE RESULTS**  
 The summary of allowed lighting power corresponds to Section C, "Compliance Results," in Form NRCC-LTI-E.

C. COMPLIANCE RESULTS									
Table Instructions: If any cell on this table says "DOES NOT COMPLY" or "COMPLIES with Exceptional Conditions" refer to Table D. for guidance.									
Lighting in conditioned and unconditioned spaces must not be combined for compliance per §140.6(b)1.	Allowed Lighting Power per §140.6(b) (Watts)					Adjusted Lighting Power per §140.6(a) (Watts)			Compliance Results
	01	02	03	04	05	06	07	08	
	Complete Building §140.6(c)1 (See Table I)	Area Category §140.6(c)2 (See Table I)	Area Category Additional §140.6(c)2G (+) (See Table J)	Tailored §140.6(c)3 (+) (See Table K)		Total Allowed (Watts)	Total Designed (Watts) (See Table F)		
<b>Conditioned:</b>	1,263.6				= 1,263.6	≥ 1,229.5	97.3	= 1,132.2	<b>COMPLIES</b>
<b>Unconditioned:</b>					=	≥	=		



## PRESCRIPTIVE APPROACH FOR OUTDOOR LIGHTING

The Prescriptive requirements for outdoor lighting apply only to hardscape areas. A lighting installation is in compliance if its installed lighting power is less than the allowed lighting power for the site. The Energy Code specifies different lighting power allowances for different lighting zones. Additionally, different lighting power allowances are defined for asphalt and concrete sites. Continuous lighting in Lighting Zone 0 is explicitly prohibited, but sites may utilize a single luminaire that is 15 watts or less at entrances to parking lots.

### General Hardscape Lighting Power Allowances

Type of Power Allowance	Lighting Zone 0 <sup>3</sup>	Lighting Zone 1 <sup>3</sup>	Lighting Zone 2 <sup>3</sup>		Lighting Zone 3 <sup>3</sup>		Lighting Zone 4 <sup>3</sup>
	Asphalt/Concrete	Asphalt/Concrete	Asphalt	Concrete <sup>2</sup>	Asphalt	Concrete <sup>2</sup>	Asphalt/Concrete
<b>Area Wattage Allowance (AWA)</b>	No allowance <sup>1</sup>	0.018 W/ft <sup>2</sup>	0.023 W/ft <sup>2</sup>	0.025 W/ft <sup>2</sup>	0.025 W/ft <sup>2</sup>	0.03 W/ft <sup>2</sup>	0.03 W/ft <sup>2</sup>
<b>Linear Wattage Allowance (LWA)</b>		0.15 W/lf	0.17 W/lf	0.4 W/lf	0.25 W/lf	0.4 W/lf	0.35 W/lf
<b>Initial Wattage Allowance (IWA)</b>		180W	250W		350W		400W

<sup>1</sup> Continuous lighting is explicitly prohibited in Lighting Zone 0. A single luminaire of 15 watts or less may be installed at an entrance to a parking area, trail head, fee payment kiosk, outhouse or toilet facility, as required to provide safe navigation of the site infrastructure. Luminaires installed shall meet the maximum zonal lumens as specified in Section 130.2(b).

<sup>2</sup> Where greater than 50% of the paved surface of a parking lot is finished with concrete. This does not extend beyond the parking lot and does not include any other General Hardscape areas.

<sup>3</sup> Narrow band spectrum light sources with a dominant peak wavelength greater than 580 nm — as mandated by local, state or federal agencies to minimize the impact on local, active professional astronomy or nocturnal habitat of specific local fauna — shall be allowed a 2.0 lighting power allowance multiplier.

Based on Table 140.7-A from the Energy Code



## CALCULATING ALLOWED LIGHTING POWER

### **GENERAL HARDSCAPE LIGHTING ALLOWANCE AND ADDITIONAL LIGHTING POWER ALLOWANCES**

Identify which Lighting Zone the project falls under (LZ0–LZ4) and if the project site is subject to any local ordinances that exceed Energy Code requirements. Guidance on how to determine Lighting Zones is provided on [page 48–49](#) of this guide. Use the plan view for all area and distance measurements, unless otherwise noted:

- 1. Calculate the illuminated hardscape area:** This area is square, centered on each luminaire or pole and is 10 times the luminaire mounting height. Subtract from this any areas within the square that are within a building, obstructed by a structure, beyond the hardscape area or beyond property lines. Also subtract any planters or landscape areas larger than 10 feet by 10 feet and are bordered by less than three sides of hardscape.
- 2. Determine the general hardscape lighting allowance:** Multiply the illuminated hardscape area (from Step 1) by the area wattage allowance (AWA) for the appropriate Lighting Zone and surface type (concrete or asphalt). If you are unsure what the surface type will be for your project, default to asphalt. See “General Hardscape Lighting Power Allowances” table for AWA values.
- 3. Calculate the perimeter length and linear wattage allowance (LWA):** Multiply the hardscape perimeter by the LWA for the appropriate Lighting Zone (see “General Hardscape Lighting Power Allowances” table). Perimeters of excluded areas may be included in calculation of the Linear Wattage Allowance (LWA).
- 4. Find the total general hardscape lighting allowance:** Add the allowed wattage from steps 2 and 3. This total is the general hardscape lighting allowance for the illuminated hardscape area.
- 5. Add any additional lighting power allowances for specific applications:** Check [Table 140.7-B](#) for any additional lighting power allowances that apply and add these to the sum from step 4. The additional allowance for specific applications is the smaller of that allowed in [Table 140.7-B](#) or the installed lighting for the specific application. Allowed lighting power for specific applications cannot be added to the total power allowance unless lighting for that specific application is installed.
- 6. Add the initial wattage allowance (IWA).** The IWA for the project lighting zone (listed in “Lighting Power Allowances”) can be added to the site’s total lighting power allowance — but just once for the entire site. For example, an Alteration project where the IWA was included in the lighting power allowance calculation for the original outdoor lighting system will not use the IWA for the lighting power allowance calculation of the altered lighting system.

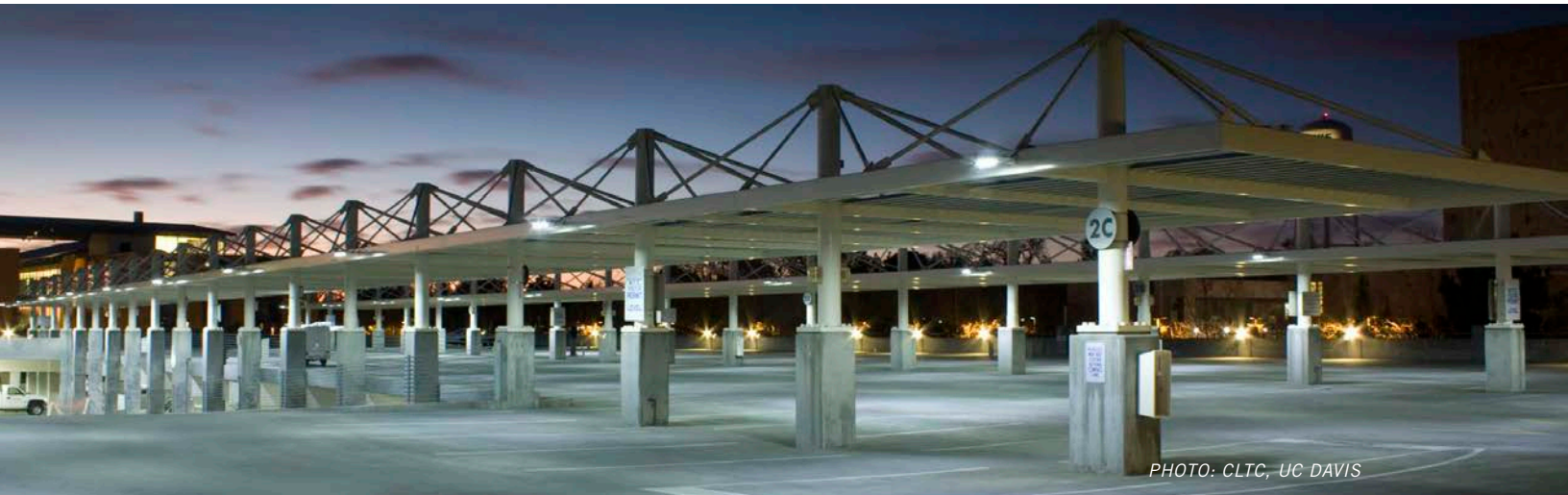

PHOTO: CLTC, UC DAVIS

#### FACTORS THAT AFFECT LIGHTING POWER ALLOWANCES

The number of luminaires, their mounting heights and their layout affect the size of the illuminated area. This size, in turn, affects the allowed lighting power.



PHOTO: CLTC, UC DAVIS

#### LUMINAIRE CLASSIFICATION BY RATED POWER Section 130.0(c)

The Energy Code considers the maximum rated power of a luminaire instead of the amount of energy used by a lamp inside of that luminaire.

For example, a luminaire that can accommodate a 100W incandescent lamp is considered a 100W luminaire for compliance purposes, even if it uses a 20W LED lamp.

#### EXCEPTIONS TO PRESCRIPTIVE REQUIREMENTS FOR OUTDOOR LIGHTING

When more than 50% of the light is part of one of the following categories, it is exempt from the Prescriptive requirements for outdoor lighting. It is important to remember that these applications are still subject to the Mandatory requirements.

- Temporary outdoor lighting
- Lighting required and regulated by the Federal Aviation Administration and the Coast Guard
- Lighting for public streets, roadways, highways and traffic signage lighting, including lighting for driveway entrances occurring in the public right-of-way
- Lighting for sports and athletic fields and children's playgrounds
- Lighting for industrial sites, including but not limited to, rail yards, maritime shipyards and docks, piers and marinas, chemical and petroleum processing plants and aviation facilities
- Lighting of public monuments, including flag poles
- Lighting of signs complying with the requirements of **Section 130.3** and **Section 140.8**
- Lighting of stairs, wheelchair elevator lifts for American with Disabilities Act (ADA) compliance and ramps that are other than parking garage ramps
- Landscape lighting
- In theme parks: outdoor lighting only for themes and special effects
- Lighting for outdoor theatrical and other outdoor live performances, provided that these lighting systems are additions to area lighting systems and are controlled by a multi-scene or theatrical cross-fade control station accessible only to authorized operators
- Outdoor lighting systems for qualified historic buildings, as defined in the California Historic Building Code (Title 24, Part 8), if they consist solely of historic lighting components or replicas of historic lighting components

## CALCULATING ACTUAL LIGHTING POWER

Add the wattage of all non-exempt lighting systems (including ballast, driver or transformer losses) to determine the actual installed lighting power (W) of an installation and ensure it is less than the allowed lighting power.

**Table 140.7-B: Additional Lighting Power Allowance for Specific Applications**

Lighting Application	Lighting Zone 0	Lighting Zone 1	Lighting Zone 2	Lighting Zone 3	Lighting Zone 4
<b>WATTAGE ALLOWANCE PER APPLICATION. Use all that apply as appropriate.</b>					
Building Entrances or Exits	N/A	9 watts	15 watts	19 watts	21 watts
Primary Entrances to Senior Care Facilities, Police Stations, Healthcare Facilities, Fire Stations and Emergency Vehicle Facilities	N/A	20 watts	40 watts	57 watts	60 watts
Drive Up Windows	N/A	16 watts	30 watts	50 watts	75 watts
Vehicle Service Station Uncovered Fuel Dispenser	N/A	55 watts	77 watts	81 watts	135 watts
Automated Teller Machine (ATM) Lighting	N/A	100 watts for first ATM, 35 watts for each additional ATM			
<b>WATTAGE ALLOWANCE PER UNIT LENGTH (W/LINEAR FT.). May be used for one or two frontage side(s) per site.</b>					
Outdoor Sales Frontage	N/A	No Allowance	11 W/linear ft.	19 W/linear ft.	25 W/linear ft.
<b>WATTAGE ALLOWANCE PER HARDSCAPE AREA (W/FT<sup>2</sup>). May be used for any illuminated hardscape area on the site.</b>					
Hardscape Ornamental Lighting	N/A	No Allowance	0.007 W/ft <sup>2</sup>	0.013 W/ft <sup>2</sup>	0.019 W/ft <sup>2</sup>
<b>WATTAGE ALLOWANCE PER SPECIFIC AREA (W/FT<sup>2</sup>). Use as appropriate, provided that none of the following specific applications shall be used for the same area.</b>					
Building Facades	N/A	No Allowance	0.1 W/ft <sup>2</sup>	0.17 W/ft <sup>2</sup>	0.225 W/ft <sup>2</sup>
Outdoor Sales Lots	N/A	0.06 W/ft <sup>2</sup>	0.21 W/ft <sup>2</sup>	0.28 W/ft <sup>2</sup>	0.485 W/ft <sup>2</sup>
Vehicle Service Station Hardscape	N/A	0.006 W/ft <sup>2</sup>	0.068 W/ft <sup>2</sup>	0.138 W/ft <sup>2</sup>	0.2 W/ft <sup>2</sup>
Vehicle Service Station Canopies	N/A	0.22 W/ft <sup>2</sup>	0.43 W/ft <sup>2</sup>	0.58 W/ft <sup>2</sup>	1.01 W/ft <sup>2</sup>
Sales Canopies	N/A	No Allowance	0.47 W/ft <sup>2</sup>	0.622 W/ft <sup>2</sup>	0.74 W/ft <sup>2</sup>
Non-sales Canopies and Tunnels	N/A	0.057 W/ft <sup>2</sup>	0.137 W/ft <sup>2</sup>	0.27 W/ft <sup>2</sup>	0.37 W/ft <sup>2</sup>
Guard Stations	N/A	0.081 W/ft <sup>2</sup>	0.176 W/ft <sup>2</sup>	0.325 W/ft <sup>2</sup>	0.425 W/ft <sup>2</sup>
Student Pick-up or Drop-off Zone	N/A	No Allowance	0.056 W/ft <sup>2</sup>	0.2 W/ft <sup>2</sup>	No Allowance
Outdoor Dining	N/A	0.004 W/ft <sup>2</sup>	0.03 W/ft <sup>2</sup>	0.05 W/ft <sup>2</sup>	0.075 W/ft <sup>2</sup>
Special Security Lighting for Retail Parking and Pedestrian Hardscape	N/A	0.004 W/ft <sup>2</sup>	0.005 W/ft <sup>2</sup>	0.01 W/ft <sup>2</sup>	No Allowance

# EXAMPLE EXERCISE: DETERMINING COMPLIANCE WITH MANDATORY AND PRESCRIPTIVE REQUIREMENTS FOR A PARKING LOT

## SCENARIO

An outdoor, asphalt parking lot 15,000 ft<sup>2</sup> in size is located in a commercial area categorized as Lighting Zone 3. The project team is planning to install three 250W luminaires (20,000 lumens each) that are mounted at a height of 25' in a 5' by 50' island in the middle of the lot paired with an astronomical timer and auto-scheduling controls. It is important to note for the hardscape calculation that the parking lot has 20' by 20' landscaped areas in each corner and the 10' by 15' driveway is included.

**What is the total power allowance for this parking lot? Does the lighting design comply with the Prescriptive and Mandatory Energy Code requirements?**

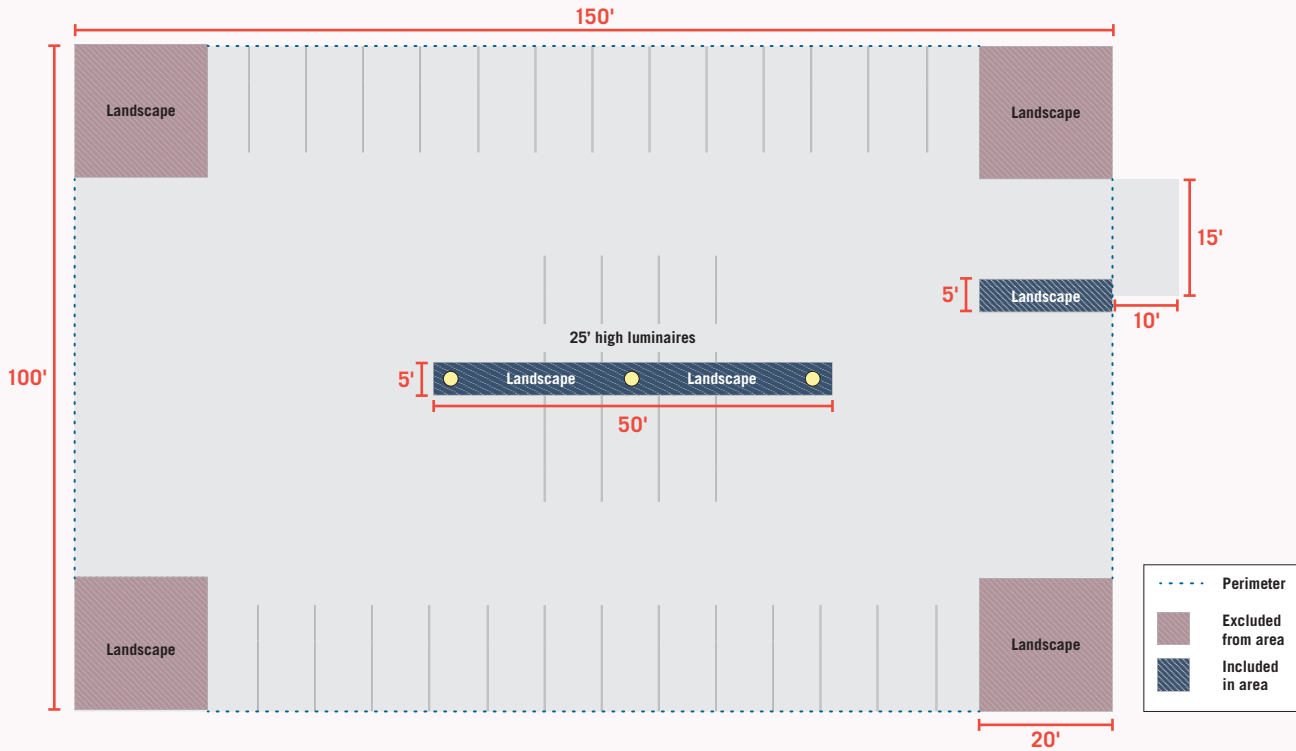

### NRCC-LTO-E, SECTION C. COMPLIANCE RESULTS

Section C, "Compliance Results," in Form NRCC-LTO-E ultimately determines whether or not the area is compliant (Column 09). By the end of this exercise, the appropriate cells for the project will be automatically filled.

#### C. COMPLIANCE RESULTS

Table Instructions: If any cell on this table says "DOES NOT COMPLY" or "COMPLIES with Exceptional Conditions" refer to Table D. for guidance.

Calculation of Total Allowed Lighting Power (Watts) §140.7 or §141.0(b)2L						Compliance Results		
01	02	03	04	05	06	07	08	09
General Hardscape Allowance §140.7(d)1 (See Table I)	+ Per Application §140.7(d)2 (See Table J)	+ Sales Frontage §140.7(d)2 (See Table K)	+ Ornamental §140.7(d)2 (See Table L)	+ Per Specific Area §140.7(d)2 (See Table M)	OR Existing Power §141.0(b)2L (See Table N)	= Total Allowed (Watts)	≥ Total Actual (Watts) (See Table F)	07 Must be ≥ 08
Cutoff Compliance (See Table G for Details)						Not Applicable		
Controls Compliance (See Table H for Details)						Not Applicable		



**NRCC-LTO-E, SECTION F. OUTDOOR LIGHTING FIXTURE SCHEDULE**

The schedule is used to fill in Section F, "Outdoor Lighting Fixture Schedule", in Form NRCC-LTO-E, which determines the actual wattage for the area.

**F. OUTDOOR LIGHTING FIXTURE SCHEDULE**

Table Instructions: For new or altered lighting systems demonstrating compliance with §140.7 (ie Table I has expanded for input), include all luminaires being installed and any existing luminaires remaining or being moved within the spaces covered by the permit application in the Table below. For altered lighting systems using the Existing Power method per §141.0(b)2L (ie Table N has expanded for input), include only new luminaires being installed and replacement luminaires being installed as part of the project scope (ie, do not include existing luminaires remaining or existing luminaires being moved).

Designed Wattage:									
01	02	03	04	05	06	07	08	09	10
Name or Item Tag	Complete Luminaire Description	Watts per luminaire <sup>1,2</sup>	How Wattage is determined	Total number luminaires <sup>2</sup>	Luminaire Status <sup>3</sup>	Excluded per §140.7(a)	Design Watts	Cutoff Req. ≥ 6,200 initial lumen output §130.2(b) <sup>4</sup>	Field Inspector
									Pass Fail
1	Pole-mounted Luminaire <input type="checkbox"/> Linear	250	Mfr. Spec <sup>1</sup>	3	New	<input type="checkbox"/>	750	Yes	<input type="checkbox"/> <input type="checkbox"/>
<b>Total Designed Watts:</b>							<b>750</b>		

**STEPS**

**NRCC-LTO-E, SECTION I. LIGHTING POWER ALLOWANCE**

Section I, "Lighting Power Allowance," in Form NRCC-LTO-E determines the total wattage allowance for the project area.

**I. LIGHTING POWER ALLOWANCE (per §140.7)**

Table Instructions: Please complete this table for areas using the allowance calculations per §140.7. General Hardscape Allowance is per Table 140.7-A while "Use it or lose it" Allowances are per Table 140.7-B. Indicate which allowances are being used to expand sections for user input. Luminaires that qualify for one of the "Use it or lose it" allowances shall not qualify for another "Use it or lose it" allowance.

01									
"Use it or lose it" Allowances (select all that apply)									
<input checked="" type="checkbox"/> General Hardscape Allowance		<input type="checkbox"/> Per Application		<input type="checkbox"/> Sales Frontage		<input type="checkbox"/> Ornamental		<input type="checkbox"/> Per Specific Area	
Table I (below)		Table J		Table K		Table L		Table M	
Calculated General Hardscape Lighting Power Allowance per Table 140.7-A (LZ 2 & 3)									
02	03	04	05	06	07	08	09	10	
Area Description	Surface Type	Area Wattage Allowance (AWA)			Linear Wattage Allowance (LWA)			Total General AWA + LWA (Watts)	
		Illuminated Area (ft <sup>2</sup> )	Allowed Density (W/ft <sup>2</sup> )	Area Allowance (Watts)	Perimeter Length (lf)	Allowed Density (W/lf)	Linear Allowance (Watts)		
Hardscape Parking Lot	Asphalt	13,550	0.025	338.75	520	0.25	130	468.75	
Reset							Add Row	Remove Last	
<b>Initial Wattage Allowance for Entire Site (Watts):</b>									<b>350</b>
<b>Total General Hardscape Allowance (Watts):</b>									<b>818.75</b>

- Calculate the illuminated hardscape area, remembering to subtract any landscape areas over 10' x 10'. The illuminated area for each 25' pole is 250' x 250', so it extends beyond the actual hardscape of the parking lot and encompasses the 150 ft<sup>2</sup> entrance. Because the lot is not adjacent to other hardscapes on the site, use the 15,000 ft<sup>2</sup> area of the lot itself, add the 15' x 10' entrance and subtract the four 400 ft<sup>2</sup> landscaped corners of the lot. This calculated value should be input in column 04 of Section I in NRCC-LTO-E.  
 $15,000 \text{ ft}^2 + 150 \text{ ft}^2 - 1,600 \text{ ft}^2 = 13,550 \text{ ft}^2$
- The general hardscape lighting allowance is automatically determined by the form by multiplying the illuminated hardscape area (Step 1) by the AWA for asphalt sites in LZ3 (found in Table 140.7-A).  
 $13,550 \text{ ft}^2 \times 0.025 \text{ W/ft}^2 = 338.8\text{W}$
- Calculate the perimeter length and input this value in column 07. The linear wattage allowance is automatically determined by the form by multiplying the hardscape perimeter length by the LWA (listed by lighting zone in Table 140.7-A).  
 $520 \text{ ft} \times 0.25 \text{ W/lf} = 130\text{W}$
- The power allowances determined in steps 2 and 3 are added together and displayed in column 10.  
 $338.8\text{W} + 130\text{W} = 468.8\text{W}$
- The IWA is added only once for the entire site. The IWA for a site in LZ3 is listed in Table 140.7-A as 350W:  
 $468.8\text{W} + 350\text{W} = 818.8\text{W}$

**NRCC-LTO-E, SECTION G. CUTOFF REQUIREMENTS (BUG) AND SECTION H. OUTDOOR LIGHTING CONTROLS**

This new construction outdoor lighting example is also required to adhere to the Mandatory requirements in **Section 130.2** for luminaire cutoff requirements and controls. See **page 50–55** of this guide for detailed requirements.

The cutoff and controls requirements are in Sections G and H of NRCC-LTO-E.

**G. CUTOFF REQUIREMENTS (BUG)**

Table Instructions: Complete this table for fixtures of  $\geq 6,200$  initial luminaire lumens indicated on Table F as needing to comply with Cutoff Requirements. Maximum lumens can be found in Title 24, Part 11, Section 5.106.8.

01	02	03	04	05	06	07	08	09	10	11	12		
Name or Item Tag	Complete Luminaire Description	Backlight Rating <sup>2</sup>			Uplight Rating <sup>2</sup>			Glare Rating <sup>2</sup>			Field Inspector		
		Mounting Height from Property Line <sup>1</sup>	Max Allowable Backlight Rating <sup>3</sup>	Backlight Rating Per Design	Lighting Type	Max Allowable Backlight Rating <sup>3</sup>	Uplight Rating Per Design	Mounting Height from Property Line <sup>1</sup>	Max Allowable Glare Rating <sup>3</sup>	Glare Rating Per Design	Pass	Fail	
1	Pole-mounted	> 2 MH from property line	No Limit	1	Area Lighting	U0	0	> 2 MH from property line	G3	1	<input type="checkbox"/>	<input type="checkbox"/>	
												<b>Reset</b>	

<sup>1</sup> FOOTNOTES: Mounting Height is labeled MH in this table

<sup>2</sup> Authority having jurisdiction may ask for luminaire cut sheets or other documentation to confirm luminaire type, uplight ratings and glare ratings used for compliance per §130.2(b).

<sup>3</sup> BUG ratings with a lower number than the 'Max Allowable' are compliant. Ex. If Max Allowable is Bug Rating is B4, then B0, B1, B2, B3 and B4 are all compliant.

**H. OUTDOOR LIGHTING CONTROLS**

Table Instructions: Complete this table demonstrating compliance with controls requirements for all new or altered luminaires installed as part of the permit application. For alteration projects, luminaires which are existing to remain (ie untouched) and luminaires which are removed and reinstalled (wiring only) do not need to be included in this table even if they are within the spaces covered by the permit application.

When an option having a \* is selected, the notes section of this table must be completed. The lighting controls section of the Compliance Summary Table on the first page will show "DOES NOT COMPLY" if the notes are left blank. For each requirement in columns 02 through 04, do not leave the field blank, instead select NA or Exempt\* from the dropdown list to indicate not applicable or an exemption.

**Mandatory Controls**

01	02	03	04	05	
Area Description	Shut-Off §130.2(c)1	Auto-Schedule §130.2(c)2	Motion Sensor §130.2(c)3	Field Inspector	
				Pass	Fail
Hardscape Parking Lot	Astronomical Timer	Yes	NA: Façade, etc. ≤ 24ft	<input type="checkbox"/>	<input type="checkbox"/>

\*NOTES: Controls with a \* require a note in the space below explaining how compliance is achieved.

EX: Not permitted by health & safety to be turned off; EXCEPTION 1 to §130.2(c).

**ANSWER**

**Total power allowance for this hardscape area: 818.8W.**

**YES — the lighting installation complies.** The parking lot luminaires use a total of 750 watts, which is less than the allowed. A more energy-efficient option, such as a 110W LED luminaire (330W total), could further improve the energy efficiency of this installation.

This lighting installation also adheres to the Mandatory requirements for luminaire cutoff requirements and controls.

**NRCC-LTO-E, SECTION C. COMPLIANCE RESULTS**

Upon completing the sections appropriate for the lighting project, Section C should be automatically populated with the calculated figures and conditionals.

**C. COMPLIANCE RESULTS**

Table Instructions: If any cell on this table says "DOES NOT COMPLY" or "COMPLIES with Exceptional Conditions" refer to Table D. for guidance.

Calculation of Total Allowed Lighting Power (Watts) §140.7 or §141.0(b)2L						Compliance Results									
01	02	03	04	05	06	07	08	09							
General Hardscape Allowance §140.7(d)1 (See Table I)	+	Per Application §140.7(d)2 (See Table J)	+	Sales Frontage §140.7(d)2 (See Table K)	+	Ornamental §140.7(d)2 (See Table L)	+	Per Specific Area §140.7(d)2 (See Table M)	OR	Existing Power §141.0(b)2L (See Table N)	=	Total Allowed (Watts)	≥	Total Actual (Watts) (See Table F)	07 Must be ≥ 08
818.75	+		+		+		OR		=			818.75	≥	750	<b>COMPLIES</b>
<b>Cutoff Compliance (See Table G for Details)</b>												<b>COMPLIES</b>			
<b>Controls Compliance (See Table H for Details)</b>												<b>COMPLIES</b>			

## SIGN LIGHTING

Both indoor and outdoor signs are addressed by the Energy Code. Control requirements are established for all illuminated signs (**Section 130.3**) and lighting power requirements are established for internally illuminated and externally illuminated signs (**Section 140.8**).

Sign lighting requirements are the same throughout the state and are independent of outdoor Lighting Zones. Additionally, sign requirements are the same in conditioned and unconditioned spaces.

Specifically, the requirements for sign lighting set minimum control requirements, maximum allowable power levels and minimum efficacy requirements. The Energy Code does not allow trade-offs between sign lighting power allowances and other end uses, including outdoor lighting, indoor lighting, HVAC, building envelope or water heating.

Application	Code Section
Signage	<b>130.3(a)2</b> Outdoor sign lighting controls
	<b>110.12(d)</b> Demand response for electronic message center (EMC) control
	<b>140.8(a)</b> Maximum allowed lighting power
	<b>140.8(b)</b> Alternate lighting sources

### Section 130.3

#### MANDATORY REQUIREMENTS

All indoor sign lighting must be equipped with an automatic time-switch control or an astronomical time-switch control.

All outdoor sign lighting must be equipped with a photo control and either an automatic time-switch control or an astronomical time-switch control.

#### SIGNS ILLUMINATED NIGHT AND DAY

All outdoor signs that are ON during the day and night must be equipped with a dimmer that can automatically reduce lighting power by at least 65% at night. This applies to signs illuminated for more than one daylight hour in addition to nighttime hours.

#### ELECTRONIC MESSAGE CENTERS

An electronic message center (EMC) with a connected lighting power load greater than 15kW must have a control that can reduce lighting power by at least 30% in response to a demand response (DR) signal.

#### EXCEPTION

*Signs inside tunnels and signs in large, permanently covered outdoor areas that are intended to be illuminated both day and night.*

#### EXCEPTIONS:

##### ELECTRONIC MESSAGE CENTERS

*Electronic message centers (EMCs) that must remain at full lighting power due to health or safety regulations are exempt and not required to respond to DR signals.*

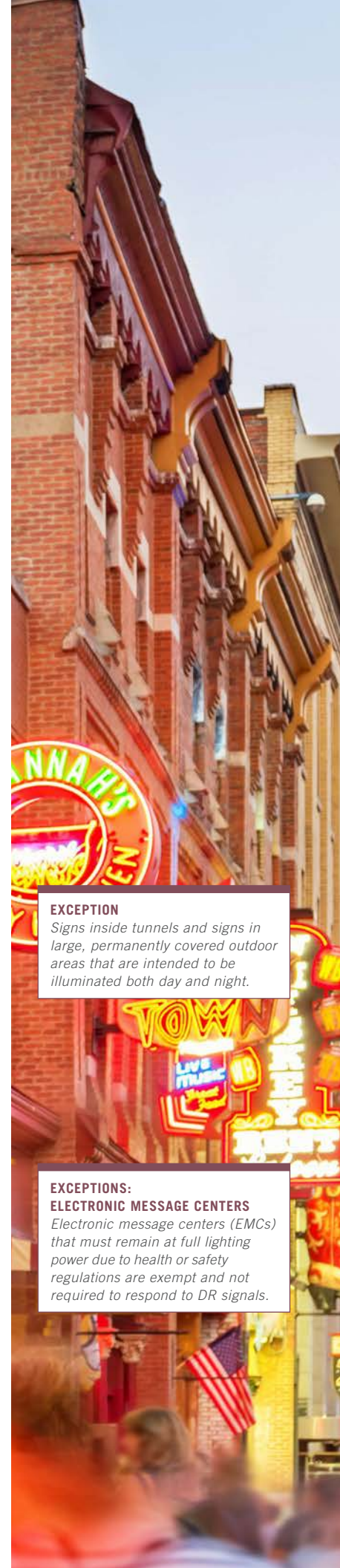

### Section 140.8

## PRESCRIPTIVE REQUIREMENTS

In addition to the Mandatory requirements for signs, the Prescriptive Approach requires that all internally and externally illuminated signs must use approved sources or comply with maximum allowed lighting power limits.

### Section 140.8(b)

#### COMPLIANT SOURCES

Signs equipped with one or more of the following source types do not need to adhere to allowed lighting power limits:

- High-pressure sodium (HPS) lamps
- Metal halide (MH) lamps that are pulse start or ceramic with a minimum ballast efficiency of 88% or pulse start MH lamps using no more than 320W, but not 250W or 175W lamps, with a minimum ballast efficiency of 80%
- Neon or cold cathode lamps with a minimum transformer or power supply efficiency of at least 75% for a rated output current less than 50mA or a minimum efficiency of 68% when the rated output current is 50mA or greater
- Fluorescent lighting systems that only use lamps with a minimum CRI of 80 or use electronic ballasts with a fundamental output frequency of at least 20kHz
- LEDs with a power supply efficiency of at least 80%
- CFLs that do not use medium screw-base sockets

### Section 140.8(a)

#### MAXIMUM ALLOWED LIGHTING POWER

Signs with source types not listed above must adhere to these lighting power limits:

- **Internally Illuminated Signs: 12 W/ft<sup>2</sup> of the illuminated sign area**  
For double-faced signs, count the area of just one face. Luminaires with permanently installed ballasts or transformers should use the operating input wattage of the lamp/ballast or lamp/transformer combination.
- **Externally Illuminated Signs: 2.3 W/ft<sup>2</sup> of the illuminated sign area**  
Luminaires with permanently installed ballasts or transformers should use the operating input wattage of the lamp/ballast or lamp/transformer combination.

## ADDITIONS, ALTERATIONS AND REPAIRS —

### Section 141.0(a)

#### ADDITIONS

Lighting plans for building Additions must meet the same Mandatory and Prescriptive or Performance standards as lighting installed for a New Construction project. If the Performance Approach is followed, the LPA for the general lighting systems in conditioned spaces may be traded off with other building features.

#### EXCEPTIONS: SECTION 140.8

Unfiltered incandescent lamps that are not part of an electronic message center (EMC), an internally illuminated sign or an externally illuminated sign.



Electronic message center (EMC)



Internally illuminated sign



Externally illuminated sign

A hybrid sign is an example of this. For instance, a sign may consist of multiple components, where some components are regulated, and some components are not regulated. A single sign structure may have a regulated internally illuminated cabinet, plus regulated externally illuminated letters which are attached to a brick pedestal, plus unregulated unfiltered incandescent "chaser" lamps forming an illuminated arrow. If the lamps are not covered by a lens, then only the control regulations (Section 130.3) apply to the sign.

Exit signs and traffic signs shall meet the requirements of the Appliance Efficiency Regulations, instead of Section 140.8.

**Section 141.0(b)2I****ALTERED INDOOR LIGHTING SYSTEMS**

Requirements for indoor lighting Alterations (**Section 141.0(b)2I**) are categorized into three types of Alterations that include at least 10% of the luminaires in the space being updated:

- **Option 1:** Comply with the indoor lighting power and lighting control requirements for New Construction (second from the right column, **Table 141.0-F**).
- **Option 2:** Alterations using 80% or less of the indoor lighting power allowances at a minimum must adhere to the lighting control requirements in the right column of **Table 141.0-F**.
- **Option 3:** Projects in small buildings or tenant spaces (5,000 ft<sup>2</sup> or less) that include 'one-for-one luminaire Alterations' to more than 50 luminaires can retrofit with new luminaires or component modifications that achieve at least 40% power reductions over pre-Alteration luminaires. The project must include the lighting controls shown in the right column of **Table 141.0-F**.

It is important to note that the following project scenarios are exempt from lighting Alteration requirements:

- Alteration of portable luminaires, luminaires affixed to movable partitions or lighting excluded as specified in **Section 140.6(a)3**.
- Any enclosed space with only one luminaire.
- Any Alteration that would directly cause the disturbance of asbestos, unless the Alteration is made in conjunction with asbestos abatement.
- Any Alteration limited to adding lighting controls, replacing only lamps or replacing only ballasts or drivers. When both the lamp and ballast/driver are replaced during the same project, the Alteration requirements apply.
- One-for-one luminaire Alteration of up to 50 luminaires either per complete floor of the building or per complete tenant space, annually.

**LIGHTING WIRING ALTERATIONS**

Alterations to lighting wiring are considered Alterations to the lighting system. Alterations to indoor lighting systems are not required to separate existing general, floor, wall, display or ornamental lighting on shared circuits or controls. New or completely replaced lighting circuits shall comply with the control separation requirements of **Section 130.1(a)3 and 130.1(c)1D**. For projects where new feeders and branch circuits are added, the voltage drop requirements from **Section 130.5(c)** apply.

**MAINTENANCE AND REPAIRS**

Routine maintenance and Repairs of lighting components, systems or equipment already installed in an existing building do not trigger the Energy Code. No compliance measures are required.

The Energy Code defines maintenance tasks and Repairs as:

- Lamp replacements
- Ballast replacements
- Replacements of lamp holders or lenses

**EXCEPTION**

*Alterations and Additions to healthcare facilities are not required to comply with Section 141.0.*

**ONE-FOR-ONE LUMINAIRE ALTERATIONS**

*'One-for-one luminaire Alterations' include replacing the entire existing luminaires, or component modification of existing luminaires.*

**EXCEPTION**

*Acceptance testing requirements are not required for indoor or outdoor Alteration projects where controls are added to 20 or fewer luminaires.*

**EXCEPTION**

*Any Alteration limited to adding lighting controls or replacing lamps, ballasts, or drivers are exempt from the lighting wiring Alteration requirements.*

## Control Requirements for Indoor Lighting System Alterations

Based on Table 141.0-F from the Energy Code

Control Specifications		Trigger	Projects Complying with Section 141.0(b)2ii	Projects Complying with Sections 141.0(b)2iii & 141.0(b)2iiii
<b>Manual Area Controls</b>	<b>130.1(a)1</b> – Be readily accessible.	Enclosed areas with ceiling-height partitions of any size. Healthcare buildings are exempt.	Required	Required
	<b>130.1(a)2</b> – Be located in the same enclosed area with the lighting fixture it controls.		Required	Required
	<b>130.1(a)3</b> – Provide separate control of general, display, ornamental and special effects lighting.		Only required for new or completely replaced circuits	Only required for new or completely replaced circuits
<b>Multi-Level Controls</b>	<b>130.1(b)</b> – Allow level of lighting to adjust up and down.	Enclosed areas 100 ft <sup>2</sup> or larger with connected lighting load that exceeds 0.5 watts per ft <sup>2</sup> . Healthcare buildings are exempt.	Required	Not Required
<b>Shut-OFF Controls</b>	<b>130.1(c)1</b> – Be controlled by an occupant sensing control, automatic time-switch control or other control capable of automatically shutting OFF all lighting when the space is typically unoccupied; provide separate controls as specified in 130.1(c)1B-D; and include a manual-ON mode for automatic time-switch controls.	All installed indoor lighting (except healthcare facilities).	Required; 130.1(c)1D only required for new or completely replaced circuits	Required; 130.1(c)1D only required for new or completely replaced circuits
	<b>130.1(c)2</b> – Countdown timer switches may be used to comply with shut-OFF control requirements in closets less than 70 ft <sup>2</sup> and server aisles in server rooms.		Required	Required
	<b>130.1(c)3</b> – Manual override for automatic time-switch controls shall turn lighting OFF after 2 hours.		Required	Required
	<b>130.1(c)4</b> – Holiday override for automatic time-switch controls shall turn lighting OFF for at least 24 hours and be able to resume normal scheduled operation.		Required	Required
	<b>130.1(c)5</b> – Spaces required to use occupant sensing controls to shut OFF all lighting.		Required	Required
	<b>130.1(c)6</b> – Spaces required to use full or partial-OFF occupant sensing controls to shut OFF all lighting.		Required	Required
	<b>130.1(c)7</b> – Spaces required to use partial-OFF occupant sensing controls.		Required	Required
	<b>130.1(c)8</b> – Hotel and motel guest rooms must have captive card key controls, occupancy sensing controls or automatic time-switch controls.		Required	Required
<b>Automatic Daylighting Controls</b>	<b>130.1(d)</b> – Automatically adjust the power of the installed lighting up and down to keep the total light level stable as the amount of incoming daylight changes.	General lighting totaling at least 120 watts in a room's combined skylit daylit zones and primary sidelit daylit zones with at least 24 ft <sup>2</sup> of glazing.  General lighting totaling at least 60 watts in the combined primary and secondary sidelit daylit zones in parking garages with at least 36 ft <sup>2</sup> of glazing or opening. Healthcare buildings are exempt.	Required	Not Required
<b>Demand Responsive Controls</b>	<b>130.1(e)</b> – Lighting reduction in response to an automated demand response signal.	Projects with more than 10,000 ft <sup>2</sup> of spaces with more than 0.5 watts per ft <sup>2</sup> . Healthcare buildings are exempt.	Required	Not Required

- Maintenance measures that do not increase energy use of the equipment being serviced
- Alterations caused directly by the disturbance of asbestos

Additionally, when 50 or less luminaires are upgraded or modified within a 12-month period in a building floor or tenant space, it is treated as a Repair rather than an Alteration, per Exception 6 to **Section 141.0(b)2I**.

**Section 141.0(b)2L**

**ALTERED OUTDOOR LIGHTING SYSTEMS**

Alterations to existing outdoor lighting systems in an application listed in **Table 140.7-A** or **140.7-B** that increase the connected lighting load must comply with the Mandatory and Prescriptive requirements as though it is a New Construction project.

Alterations to existing outdoor lighting systems in an application listed in **Table 140.7-A** or **140.7-B** that do not increase the connected load of the outdoor lighting system vary based on the number or percentage of the lighting fixtures being changed, moved or replaced, per the table below.

**Section 141.0(b)2M**

**SIGN ALTERATIONS**

Certain Alterations to existing signs, whether internally or externally illuminated, require compliance with the Energy Code for sign lighting (**Section 140.8**):

1. The connected lighting load is increased
2. Over 50% of the ballasts are replaced and rewired
3. The sign is relocated, either on the same site or to a new site

**EXCEPTION**

Acceptance testing requirements are not required for indoor or outdoor Alteration projects where controls are added to 20 or fewer luminaires.

**RETROFITTING LUMINAIRES**

[energycodeace.com/download/34712/file\\_path/fieldList/TriggerSheet.NR-Ext.Light.2019](http://energycodeace.com/download/34712/file_path/fieldList/TriggerSheet.NR-Ext.Light.2019)

If retrofitting an existing luminaire with new technology (i.e., rewiring HID shoebox with LED technology) in which the fixture head remains, it is not considered an Alteration unless the connected load is increased (see below). If the fixture head is being replaced, but the pole is remaining, this is considered a luminaire Alteration.

**EXCEPTIONS**

Replacement of parts of an existing sign, including replacing lamps, the sign face or ballast, that do not require rewiring or that are done at a time other than when the sign is relocated is not considered an Alteration.

**Altered Outdoor Lighting Systems — Triggers and Requirements**

Alteration Compliance Method Used	Mandatory Lighting Controls Required					Prescriptive Wattage Allowance Required
	Luminaire Cutoff (i.e., BUG) when ≥ 6,200 lumens	Daylight Available	Motion Sensing for Parking or Sales Lot luminaires ≤ 24 feet above the ground and > 40 watts	At least one of these controls when > 24 feet above the ground or if not a Parking or Sales Lot luminaire at any height		
Acceptance testing requirements of Section 130.4 are not required for Alterations where lighting controls are added or altered to control ≤ 20 luminaires for the entire permitted project (indoor, outdoor and sign lighting)	Section 130.2(b)	Section 130.2(c)1	Section 130.2(c)3	Automatic Scheduling	Motion Sensing	Section 140.7
Altering < 10% or ≤ 4 luminaires	Yes	No	No	No	No	No
Altering 10–49% or ≥ 5 luminaires	Yes	Yes	Yes	Either this..	Or this	No
Altering ≥ 50% or ≥ 5 luminaires not using reduced wattage exception	Yes	Yes	Yes	Either this..	Or this	Yes
Altering ≥ 50% or ≥ 5 luminaires using reduced wattage exception	Yes	Yes	Yes	Either this..	Or this	No
Adding to the Connected Load	Yes	Yes	Yes	Yes	Yes	Yes



AL

Local Sourdough

Splendid Bread

Eat From The Ground

Better on a Bun





## CHAPTER 5

# REQUIREMENTS AND RECOMMENDATIONS

## DESIGNING TO THE ENERGY CODE

The Energy Code allows designers and builders to choose from a variety of lighting strategies and technologies. Options are available across a broad range of price points and can suit a variety of aesthetics. The sample lighting designs presented in this chapter represent just some of the many possibilities on the market today.

### MINIMIZE LIGHTING POWER DENSITY, MAXIMIZE CONTROL

Designing commercial or nonresidential buildings to meet or exceed the Energy Code requires lighting measures that maximize the use of controls to minimize lighting power density. Following this approach reduces lighting energy use.

These energy efficiency steps are necessary for California to meet its ambitious goal of decarbonizing buildings and reducing greenhouse gas emissions, with a target of 40% below 1990 levels by 2030.

Lighting should help people in the space perform their tasks effectively and comfortably. In most office applications, this involves maximizing illumination while minimizing the visibility of light sources to allow employees to focus on the workspaces being lit rather than the lighting itself. Energy savings can be achieved while maintaining the quality of lighting for occupants' comfort and satisfaction.

A critical step in lighting design is determining the visual needs of the space and identifying the type of lighting to use. This step helps inform which energy-efficient lighting technologies and control strategies to use.

This chapter discusses how the Energy Code applies to ambient lighting, task lighting, daylighting and transitional spaces. Recommendations for nonresidential applications are provided to help design with the lighting Energy Code requirements in mind, considering the building's architecture, atmosphere and aesthetics.



INTERNATIONAL  
WELL  
BUILDING  
INSTITUTE™

THE WELL STANDARD  
[v2.wellcertified.com](https://v2.wellcertified.com)

*The WELL lighting standard aims to create lighting environments that are optimal for visual, mental and biological health.*

## ARCHITECTURE

Lighting can emphasize, soften or balance certain architectural features. Examples include making a small boutique feel more spacious, playing up (or playing down) the texture of a wall or accenting coves and valances. It is also helpful to consider the materials used in the space; for example, dark, polished granite reflects light differently than wood or brick.

## ATMOSPHERE

It is recommended that the atmosphere of your project be considered at the start of your lighting design. Consider what activities or tasks will take place in different areas. High-contrast lighting is typically used in upscale boutiques, while higher, more uniform light levels are commonly found in big box retail stores to support high-volume sales tasks.

## AESTHETICS

The style, or aesthetic, of the lighting design should complement the building's style. It should suit its demographic, whether it is classic or contemporary aesthetic; youthful or sophisticated; cutting-edge or family-oriented.

Light source choices should include the careful consideration of an appropriate CCT and color rendering ability. Recently, the ability to adjust the CCT has become an option to consider. This category of products allows users to adjust intensity and color while offering a way to change the visual appearance of the space.

# APPLYING REQUIREMENTS FOR OFFICE LIGHTING

---

## LAYERED LIGHTING

Many nonresidential spaces rely on general lighting, where ceiling-mounted luminaires provide an overall level of illumination for all space uses. This strategy often results in a level of illumination that is sufficient for tasks in all locations, regardless of whether tasks are being performed or not. Recent studies have shown that reducing this general, ambient lighting and using localized light for specific visual tasks creates a more comfortable experience and can significantly reduce energy use.

In partnership with lighting manufacturers and the Energy Commission's Public Interest Energy Research (PIER) Program, CLTC evaluated the benefits of a layered lighting design for office applications. The studies found that including LED task lighting as a primary layer of lighting in offices resulted in a 50% savings in lighting energy and overwhelming user satisfaction. A summary of some of the research conducted follows:

### **INTEGRATED LIGHTING SYSTEM**

Task and ambient lighting, an effective strategy to illuminate office spaces, is a total systems approach. Dimmable overhead luminaires provide the majority of the lighting, supplemented by vertical surface and task lighting. This approach achieves significant energy savings by reducing the overhead lighting load without sacrificing user comfort and visual acuity.



### THE BENEFITS OF LED TASK LIGHTING

The “Portable Office Lighting Systems Final Report” summarizes the research to design, develop and test prototype workstation luminaires. The report implemented lighting controls in these lamps to provide both workstation and office-level lighting control.

### COMPLIANCE REQUIREMENTS

LPD requirements for office-related areas now range from 0.5 to 0.7 W/ft<sup>2</sup>. This LPD maximum can be achieved by carefully adding lighting only where it is needed and by using LED technologies where possible. Review **Table 140.6-C** in the Appendix for the allowed lighting power densities in the Area Category Method.

### ★ RECOMMENDATIONS

- 1. Visual Comfort and Uniformity:** Use indirect lighting to minimize glare on computer screens and task lighting to provide users light when and where it is needed. Indirect lighting illuminates the ceiling, which in turn reflects light down to the vertical surfaces, task areas and floor. If the lighting design provides uniform distribution, the resulting illumination can be diffused, soft and nearly shadow-free.
- 2. Vertical Illumination:** Vertical illumination is the amount of light output per unit area measured on a vertical surface. Adding lighting for vertical surfaces where the task and ambient strategy is applied reduces contrast ratios and gives the space a softer, more appealing visual appearance. This additional effect also offers energy reduction opportunities when the luminaires illuminating the vertical surfaces are controlled in a separate lighting layer. This layer can be dimmed or shut off during typically vacant periods or during a demand response event.
- 3. Networked Controls:** In an open office environment, overhead ambient lighting is typically controlled in large zones. As a result, large areas of a building may be illuminated for long periods of time, regardless of occupancy. Significant energy and maintenance savings can be achieved by using a combination of (1) low ambient lighting, (2) zonal controls for smaller areas, (3) high-quality task lighting and (4) personalized controls. Many controls solutions involve connecting all light points into a network using either wired or wireless communication between sensor and luminaires or from luminaire to luminaire if integrated controls are used. Not all networked systems accurately collect information about energy use. Some systems do not collect or store any information and are intended to function as a hardware-based system only.

The Energy Code does not require that networked lighting controls be used to meet the Mandatory Measures. Yet, many current systems have standard features that meet and exceed the measures in **Section 130.1** and utilize the Electric Power Distribution Systems separation requirements in **Section 130.5**.

#### PORTABLE OFFICE LIGHTING SYSTEMS

Detailed information on portable office lighting systems research is available in the Final Report.

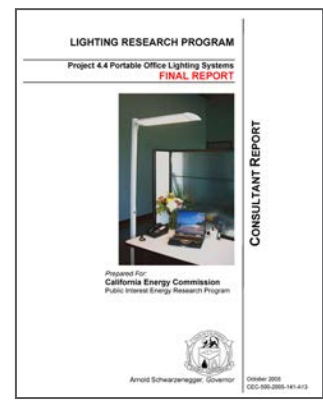

#### ZONAL CONTROLS FOR SMALLER AREAS

Zonal occupancy controls in open offices greater than 250 ft<sup>2</sup> are eligible for a Power Adjustment Factor. See **page 61** of this guide for details.

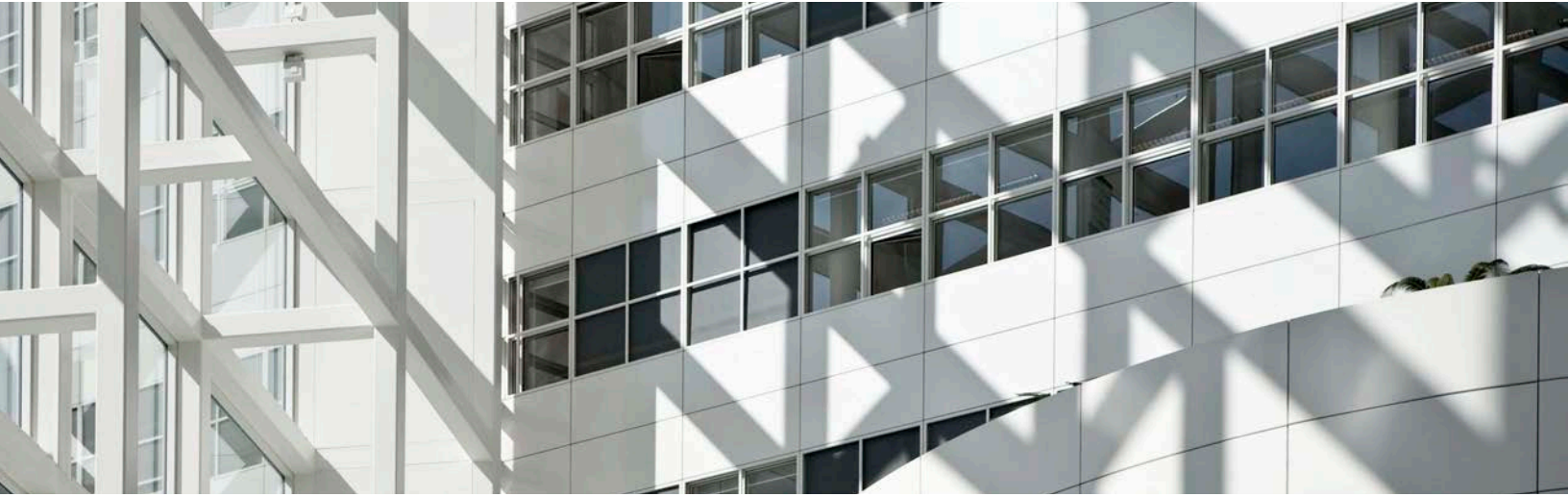

## MANAGING DAYLIGHT

### IES' RECOMMENDED PRACTICE FOR DAYLIGHTING BUILDINGS (RP-5-13) [cltc.ucdavis.edu/publication/ies-rp-5-13-recommended-practice-daylighting-buildings](http://cltc.ucdavis.edu/publication/ies-rp-5-13-recommended-practice-daylighting-buildings)

More information about this guide can be found at the link above.

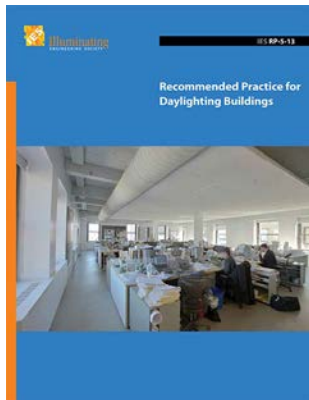

### ☑ COMPLIANCE REQUIREMENTS

Mandatory automatic daylighting controls are required in indoor spaces that have 24 ft<sup>2</sup> or more of glazing and 120 watts or more of general illumination in the combined primary sidelit and skylit daylit zones. Not all buildings will realize the maximum benefit from adding daylighting controls due to the building's position or outside obstructions. Not all measures are required for all projects, and there are many exceptions. Review **Section 130.1(d)** (see **page 42** of this guide) and **Sections 141.0(b)2I** with **Table 141.0-E** (see **page 85** of this guide) to determine what each project mandates.

### ★ RECOMMENDATIONS

Daylighting in commercial buildings can reduce electricity use for lighting by up to 50% or more but also presents complex challenges. The IES' Recommended Practice for Daylighting Buildings (RP-5-13) provides up-to-date technological solutions and data for addressing the challenges of daylighting while maximizing its benefits. RP-5-13, which is an authoritative reference guide for architects, engineers and lighting designers, includes information on daylight design techniques, delivery methods, glazing systems, shading techniques, control strategies and daylight performance simulation tools.



### DAYLIGHT HARVESTING FOR COMMERCIAL BUILDINGS GUIDE [cltc.ucdavis.edu/publication/daylight-harvesting-commercial-buildings-guide](http://cltc.ucdavis.edu/publication/daylight-harvesting-commercial-buildings-guide)

The California Lighting Technology Center recently published the *Daylight Harvesting for Commercial Buildings* guide. This publication provides detailed guidance towards meeting and exceeding the Energy Code for daylight harvesting.

Daylight design guidelines and the associated Energy Code are provided in an easy to read, side-by-side layout, organized into sections for each building-related discipline that impacts daylight performance, including building siting, architectural and interior design, construction, commissioning and operation.

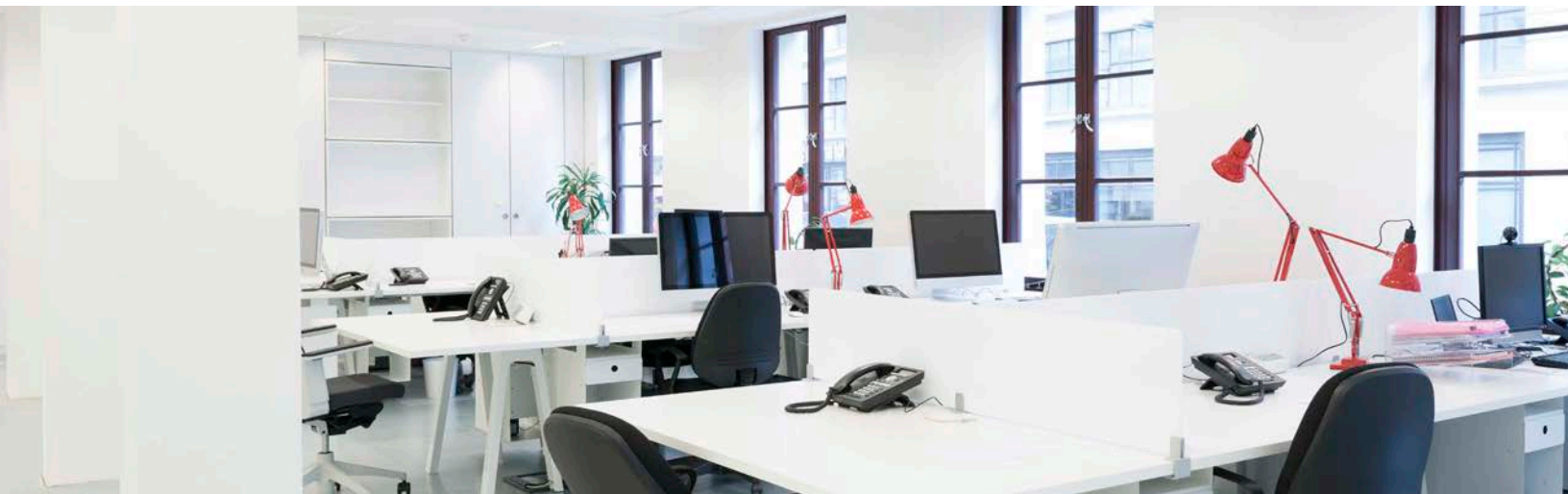

## TASK LIGHTING

### ✓ COMPLIANCE REQUIREMENTS

Task lighting can play a critical role when designing a compliant lighting system. Today, task lighting is available at a reasonable cost with current LED products.

In office space projects that trigger the plug load control requirements in **Section 130.5**, task lighting should be powered from occupancy-controlled outlets. Additionally, task lighting can be integrated into networked controls for maximum benefit.

### ★ RECOMMENDATIONS

Occupants have varying lighting requirements. Different visual tasks demand variations in lighting to produce ideal lighting conditions. Computer monitors require diffused, ambient light with low screen glare effects, while printed materials require more light directed to a specific task plane (typically a desk surface) to avoid eye fatigue caused by low light levels. These task requirements drive target illuminance levels. Task lighting equipped with personal control helps to meet visual task requirements and should be included in the lighting design.

#### GLARE FROM VEILING REFLECTIONS

*Glare from veiling reflections off a computer monitor competes with the brightness of the screen and produces visual discomfort for users.*



## LARGE RETAIL AND OUTLET STORES

### ☑ COMPLIANCE IN PRACTICE

#### *Section 130.1(a)*

##### **SWITCH PLACEMENT**

In most areas, luminaires and manual ON/OFF controls are required to be located in close proximity to each other. This may work well in office applications, but in retail settings, unauthorized persons should not have access to the lighting controls. In malls, retail and wholesale sales floors, the lighting control is required to be located so that a person using the lighting control can see the lights or area controlled by that lighting control; the switch does not have to be in that immediate vicinity and accessible to the public. Alternatively, it is permitted to use a lighting controls system where that area of the store is annunciated through the control interface, and the person controlling the lighting can see the effect of their actions remotely.

#### *Section 130.1(a)*

##### **FLOOR, WALL AND WINDOW DISPLAYS**

Floor, wall and window displays are required to be switched separately. In the example on the next page, a separate switch in view of the window display lighting controls the window displays at the front of the store. Case display, ornamental and special effects lighting are also required to be switched separately. Controlled layers of lighting should be on circuits of 20 amps or less.

#### *Section 130.0(c)*

##### **TRACK LIGHTING**

Line-voltage track lighting is popular in retail because it can be adjusted to suit changing displays and focus attention on a small area. Use **Section 130.0(c)6** to determine how much power to count towards the actual lighting power budget. More information on track lighting luminaire classification and power determination is on **page 63** of this guide.

##### **ADDITIONAL LIGHTING POWER ALLOWANCES**

In areas approved to use the Tailored Method of the Prescriptive Approach, displays with very valuable merchandise are eligible for additional lighting power. Under the Tailored Method, additional lighting power also includes wall display, floor display and ornamental lighting.

### ★ RECOMMENDATIONS

#### **FLATTERING FITTING ROOMS**

High-CRI luminaires enhance the colors and textures of merchandise. Choose luminaires that provide soft, even distribution and consider lighting mirrors along both vertical edges to prevent unflattering shadows. In small fitting rooms, cove lighting located behind mirrors can help make these spaces feel larger.

#### **EXAMPLE LIGHTING DESIGN**

An example lighting schedule and floor plan of a large retail or outlet store is provided on the next page. Examples of appropriate switch placement, display lighting and track lighting are shown.



## LIGHTING SCHEDULE

Symbol	Luminaire Type	Lamp	Quantity	Watts	Total Watts	Efficacy (lm/W)
⊕	Pendant	Induction	5	55	275	65
⊕	Decorative pendant	Dedicated LED	6	10	60	60
○	6" Recessed downlight	Dedicated LED	10	12	120	67
▬	1 x 4 Ceiling-mounted troffer	Dedicated LED	4	38	152	105
⊖ ⊖ ⊖	8' track with 5 heads	LED track heads	8	240 <sup>1</sup>	1920	47
⊖ ⊖ ⊖	4' track with 3 heads	LED track heads	1	120 <sup>1</sup>	120	47

**Controls**    Ⓢ Manual ON/OFF switch with dimming

**Installed Watts Total: 2,647W**

Ⓢ Automatic time switch connected to all lighting circuits

The track lighting wattage claimed for compliance purposes used the method described in Section 130.0(c)6Ai (30 watts per linear foot of track lighting). For compliance form NRCC-LTI-E, check the track lighting option in column 03 and fill out Section G (Modular Lighting Systems) to specify how wattage is determined.

### F. INDOOR LIGHTING FIXTURE SCHEDULE

Table Instructions: Include all permanent designed lighting and all portable lighting in offices.

**1 TRACK LIGHTING:**

#### Designed Wattage: Conditioned Spaces

01 Name or Item Tag	02 Complete Luminaire Description	03 Modular (Track) Fixture	04 Small Aperture & Color Change <sup>1</sup>	05 Watts per luminaire <sup>2</sup>	06 How Wattage is determined	07 Total number luminaires	08 Exempt per §140.6(a)3	09 Design Watts	10 Field Inspector	
									Pass	Fail
5	8' track with 5 heads	<input checked="" type="checkbox"/>	<input type="checkbox"/>	240	See Table G	8	<input type="checkbox"/>	1,920	<input type="checkbox"/>	<input type="checkbox"/>
6	4' track with 3 heads	<input checked="" type="checkbox"/>	<input type="checkbox"/>	120	See Table G	1	<input type="checkbox"/>	120	<input type="checkbox"/>	<input type="checkbox"/>

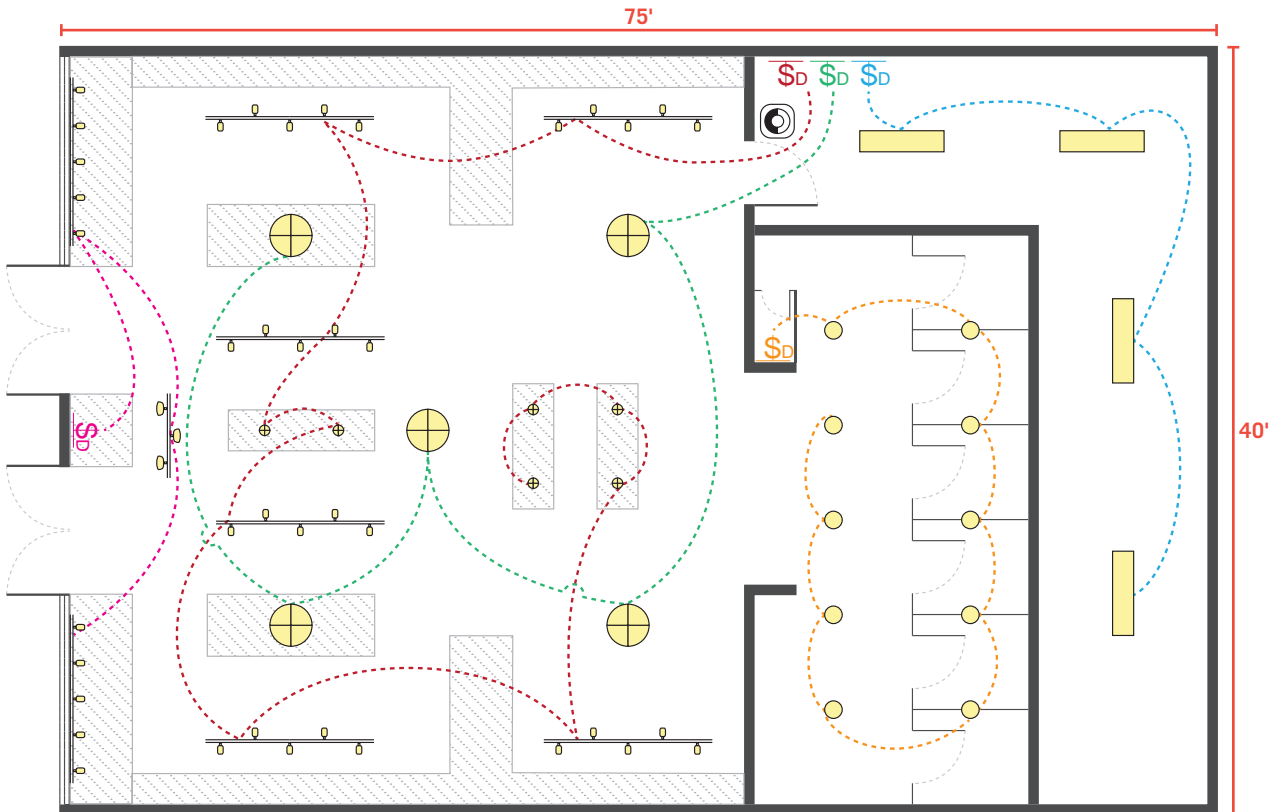

## BOUTIQUES AND SMALLER STORES

### ✓ COMPLIANCE IN PRACTICE

*Section 130.1(c)*

#### **OCCUPANCY CONTROLS**

Placing occupancy sensors in stock rooms complies with the Energy Code for lighting controls in secondary spaces. Occupancy sensors will also turn lights ON and OFF automatically for employees who typically have their hands full when entering or exiting these spaces.

### ★ RECOMMENDATIONS

#### **ACCENT LIGHTING**

Use accent lighting strategically to draw customers' attention to certain displays and enhance merchandise details.

#### **CONTRAST BETWEEN AMBIENT AND DISPLAY LIGHTING**

Keeping lower ambient light levels heightens the impact of display lighting and accent lighting in boutiques. This high-contrast lighting design strategy conveys a more upscale atmosphere to customers and saves energy.

#### **COLOR-SHIFTING DISPLAY LIGHTING**

Consider tunable lighting to enhance displays and command customers' attention. Color-tunable LED lighting is one effective option.

#### **WINDOW DISPLAYS**

Window displays are critical for attracting customers. Position lights to avoid glare in spaces with large front-facing windows.

#### **EXAMPLE LIGHTING DESIGN**

An example lighting schedule and floor plan of a boutique or smaller store is provided on the next page. Examples of appropriate occupancy controls, accent lighting, display lighting and window displays are shown.



#### ADVANCED LIGHTING IN SMALL RETAIL Davis, California

[cltc.ucdavis.edu/publication/20150609-pge-led-linear-retrofit-solutions-alcs-retail](http://cltc.ucdavis.edu/publication/20150609-pge-led-linear-retrofit-solutions-alcs-retail)

CLTC evaluated the performance of LED linear retrofit kits paired with advanced lighting control systems with a small retailer, Watermelon Music, located in Davis, California.

A retrofit LED lighting system including advanced controls was designed to meet IES-recommended light levels for retail applications. Measurement and verification of the systems was conducted to quantify its photometric performance and the energy savings of the approach. By adding the controls to the dimmable LED light source, an additional 25.2% savings were monitored at the small retail store. Full results are available in the report.



## LIGHTING SCHEDULE

Symbol	Luminaire Type	Lamp	Quantity	Watts	Total Watts	Efficacy (lm/W)
○	6" Recessed downlight	Dedicated LED	12	9.5	114	67
⊕	4" Adjustable recessed downlight	Dedicated LED	16	11	176	54.5
—	48" Cove lighting	Dedicated LED	3	14	42	98
▬	1 x 4 Ceiling-mounted troffer with integrated occupancy sensor	Dedicated LED	1	38	38	105
⓪⓪⓪	4' Track with 3 heads	LED track heads	3	120 <sup>1</sup>	360	47

**Controls**     Ⓞ Manual ON/OFF switch with dimming

**Installed Watts Total: 730W**

Ⓞ Automatic time switch

**<sup>1</sup> TRACK LIGHTING:** The track lighting wattage claimed for compliance purposes used the method described in Section 130.0(c)6Ai (30 watts per linear foot of track lighting). For compliance form NRCC-LTI-E, check the track lighting option in column 03 and fill out Section G (Modular Lighting Systems) to specify how wattage is determined.

### LUMINAIRES WITH INTEGRATED CONTROLS

Occupancy-based lighting controls can save significant amounts of energy in areas such as stock rooms, which are often characterized by highly intermittent occupancy patterns. Integrated, occupancy-based lighting controls offer the largest opportunity for energy and cost savings. Integrate dimming or multi-level stepped lighting controls that include a lower light setting for periods of inactivity (to support safety) and additional settings to provide light levels for different activities.



PHOTO: ACUITY BRANDS

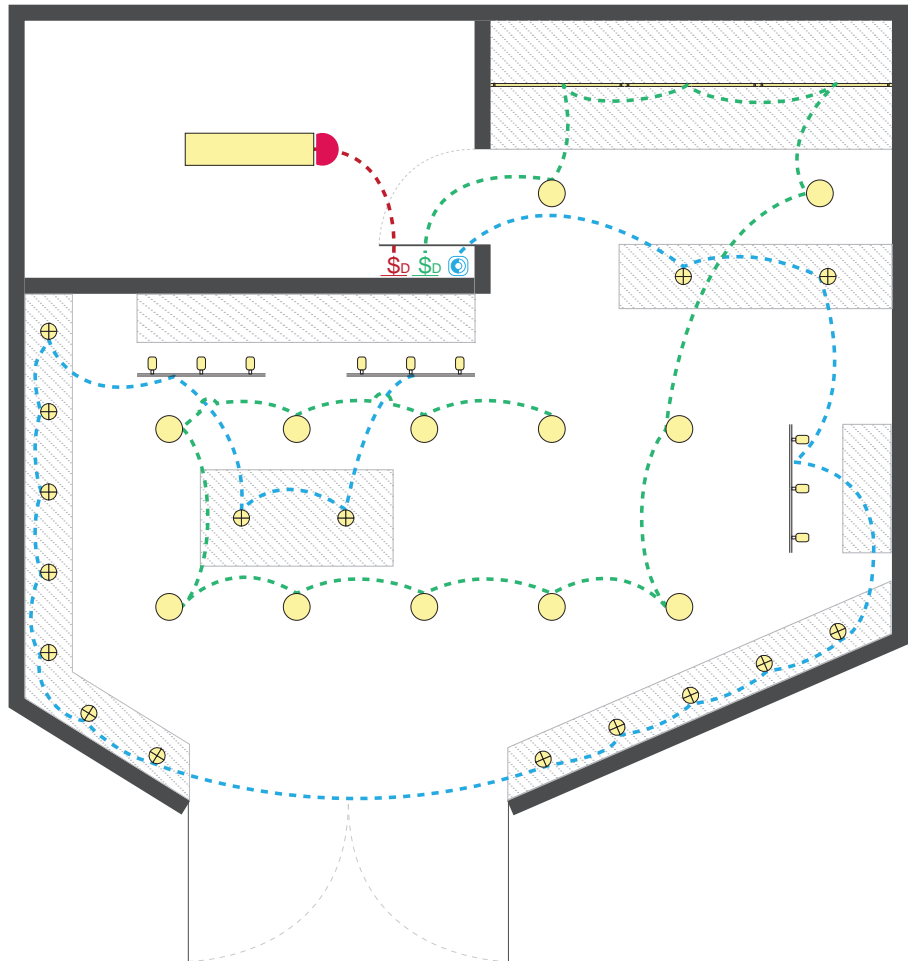

## COMMERCIAL RESTROOMS

### ☑ COMPLIANCE IN PRACTICE

#### *Section 130.1(a)2* **MANUAL CONTROLS**

In public restrooms with two or more stalls, a manual switch that is only accessible to authorized personnel may be used. All other applicable lighting controls for the space are still required. Public restrooms are exempt from multi-level controls but must have occupancy sensing controls that shut OFF all lighting.

### ★ RECOMMENDATIONS

#### **OCCUPANCY SENSORS**

Ultrasonic occupancy sensors can detect occupants around corners. This prevents lights from turning OFF while the space is in use. Ceiling-mounted dual-technology sensors that include both ultrasonic and passive infrared (PIR) technologies are available to assure the lighting stays ON when it is needed.

#### **VANITY LIGHTING**

Flattering lighting around mirrors contributes to customers' overall retail experience. Vertical bath bars placed parallel to mirrors minimize unflattering shadows.

#### **EXAMPLE LIGHTING DESIGN**

An example lighting schedule and floor plan of a commercial restroom is provided on the next page. Examples of appropriate controls, occupancy sensors and vanity lighting are provided.



## LIGHTING SCHEDULE

Symbol	Luminaire Type	Lamp	Quantity	Watts	Total Watts	Efficacy (lm/W)
	2 x 4 Recessed troffer	Dedicated LED	4	22	88	100
	3' Vertical bath bar	Dedicated LED	8	15	120	60
	6" Recessed downlight	Dedicated LED	1	9.5	9.5	67

**Controls**     Manual ON/OFF switch with dimming     Vacancy Control    **Installed Watts Total: 217.5W**

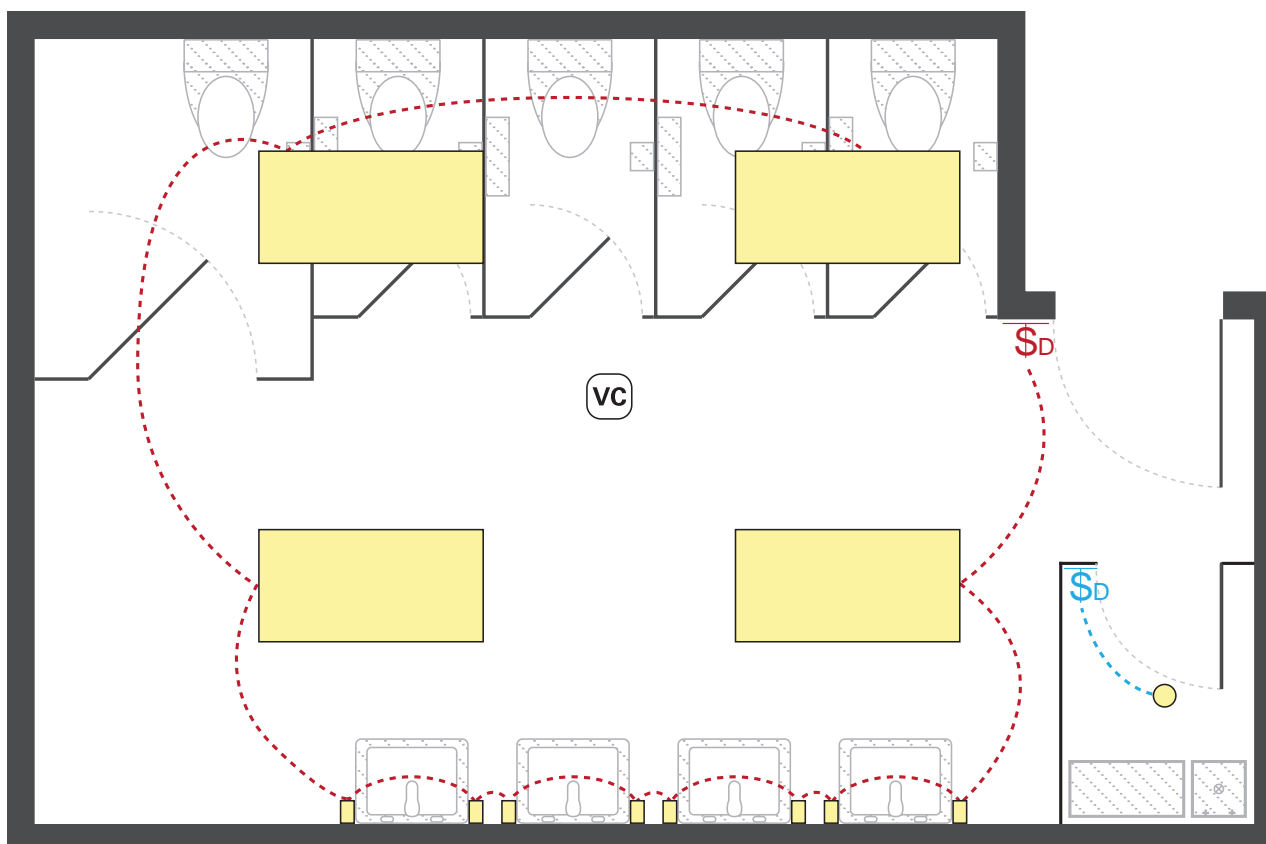

## EDUCATIONAL FACILITIES

### ✓ COMPLIANCE IN PRACTICE

There are several specific requirements pertaining to classrooms. Classrooms must have partial-ON occupancy sensors or vacancy sensors if also meeting **Section 130.1(b)**. Classrooms with a connected load of 0.7 W/ft<sup>2</sup> or less can have one control step between 30–70% instead of full multi-level control requirements.

### ★ RECOMMENDATIONS

#### **ENERGY SAVINGS**

Educational facilities often encompass many functional areas and end users. Traditional office spaces, classrooms, conference rooms and cafeterias are all typical areas in an educational facility. For this reason, it is recommended that continuous dimming light sources be paired with dimmers, occupancy sensors and automatic daylighting controls as appropriate. It is also an ideal application for the use of spectrally-tunable luminaires.

#### **DIMMING DEVICES**

It is critical to specify a dimmer that is compatible with the light source you are installing. This means you should reference the list of compatible dimmers provided by the manufacturer for the light source when designing your new system.

#### **OCCUPANCY SENSORS**

The correct specification of occupancy sensing technology is critical to the success of your lighting system. It is recommended that the use of the space be considered from a size and coverage pattern perspective, as well as a mounting location perspective. Use of sound based technologies near air ducts will consistently result in false triggers and can turn your light system ON during periods of vacancy. It is also an acceptance requirement, per **NA 7.6.2.2**, that occupant sensing lighting controls be no closer than four feet from a HVAC diffuser.

#### **AUTOMATIC DAYLIGHTING CONTROLS**

Educational facilities often incorporate sidelit and skylit daylighting into the building's design. For this reason, it is important to deploy a fully-functional automatic daylighting control system so teachers and students alike can enjoy natural daylight conditions when it is available.



#### **SPECTRALLY-TUNABLE LUMINAIRES**

Spectrally-tunable luminaires allow the user to specify the warmness or coolness of the light. For educational facilities, this feature is ideal for setting a mood or scene during periods of scheduled activities such as recess, study hall or testing.



## LIGHTING SCHEDULE

Symbol	Luminaire Type	Lamp	Quantity	Watts	Total Watts	Efficacy (lm/W)
	Linear pendant with wireless communication and integrated occupancy sensor	Dedicated LED	18	38	684	100

**Controls**      Manual ON/OFF switch with dimming      Automatic Daylighting Control with wireless communication

### APPLYING SKYLIT DAYLIT ZONE CALCULATIONS

The floor plan below has a circular skylight with a diameter of 4 feet, an average ceiling height of 20 feet, and the desks are 2.5 feet tall.

#### SKYLIT DAYLIT ZONE

1. Define the shape of the skylight. The circular skylight will produce a circular daylit zone.
2. Determine the average ceiling height. The average ceiling height is 20 feet.
3. Multiply the CH by 0.7 and add the value in all directions around the skylight. The skylit zone is 14 feet in all directions. The luminaires within the skylit zone must be paired with automatic daylighting controls.

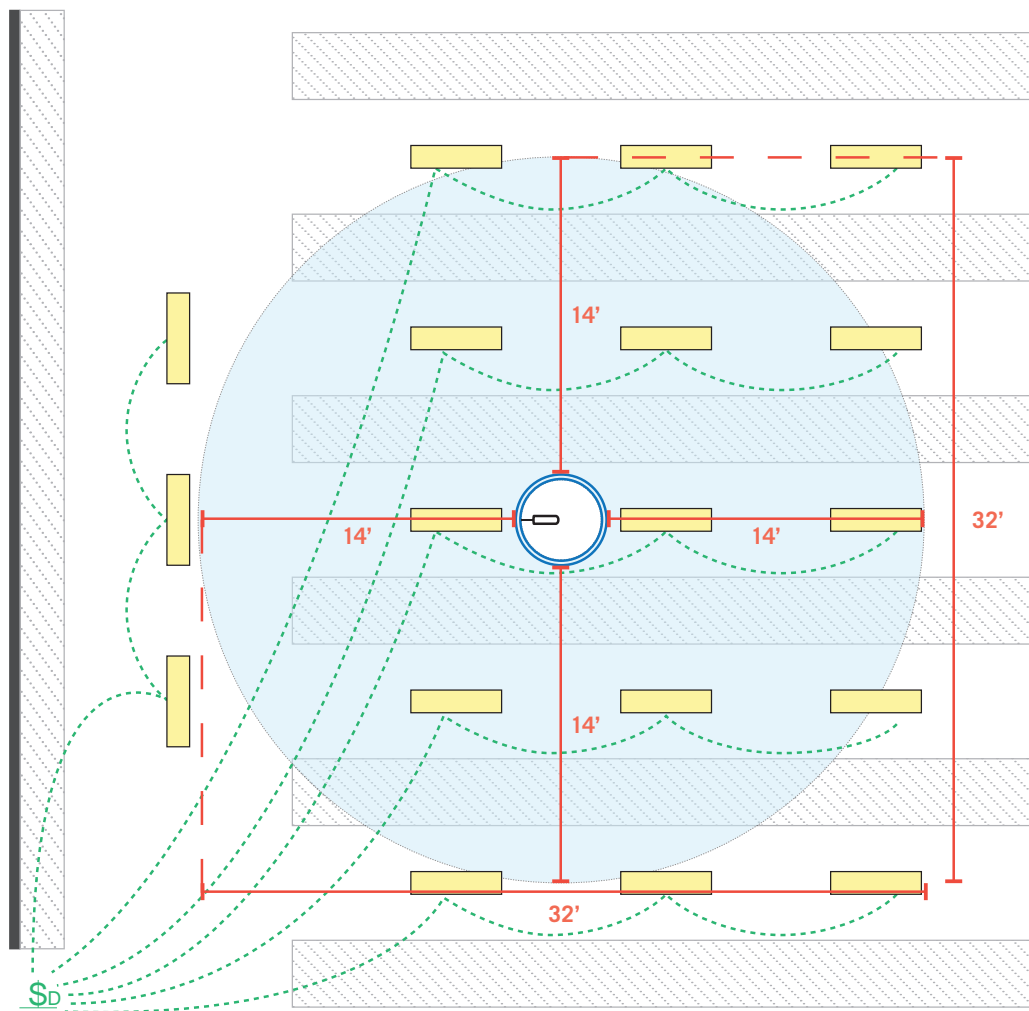

## TRANSITIONAL SPACES

### ✓ COMPLIANCE IN PRACTICE

Lighting power for stairwell and corridor luminaires should be automatically reduced by at least 50% during vacant periods. Recommended light levels should be restored when occupants are detected from either direction. At 50% power, general lighting is often well above minimum levels required for egress lighting (see [page 38](#) of this guide). After typical occupied hours, general lighting in stairwells and corridors can be shut OFF for deeper energy savings, assuming the lights will turn back ON to 100% when occupied. Only partial-OFF is required by the Energy Code.

### ★ RECOMMENDATIONS

#### RETROFIT OPTIONS

Bi-level luminaire retrofits are easy to implement and are designed to provide safe, reliable and efficient lighting. If fluorescent luminaires are in good condition, a lamp-and-ballast retrofit with the addition of an external sensor technology will provide the bi-level functionality to meet the Energy Code. These luminaires will also need to be completely shut OFF after occupied times, per [Section 130.1\(c\)](#).

#### LED LUMINAIRES WITH INTEGRATED CONTROLS

There is an evolving product base of bi-level LED luminaires with integrated sensors made specifically for this application. Some products have the ability to communicate between luminaires or back to a centralized system through a network. If luminaires are old and need replacing, the best long-term approach is installing new, dedicated LED strip luminaires with integrated dimming drivers rather than retrofitting.

#### SENSOR OPTIONS

Ultrasonic sensors typically offer a better level of detection in constricted stairwell configurations compared to passive infrared (PIR) sensors. PIR technology has proven effective when multiple sensors are integrated within the luminaire with different detection angles. In either case, make sure that the sensor technology is appropriately installed and commissioned for effective lighting control. An LED retrofit kit that supports bi-level functionality offers another option.

Stairwells are often located at the perimeter of buildings where large windows may offer a significant opportunity for daylight harvesting. Photosensors need to be carefully placed in stairwells. Luminaire-integrated photosensors provide lighting control on a per-luminaire basis. Alternatively, a single photosensor can be used to control multiple luminaires. Daylight harvesting systems can be cost-effective in spaces that receive enough daylight, but like most lighting controls, they require careful installation and proper calibration to function properly.

PHOTO: ACUITY BRANDS





PHOTO: CLTC, UC DAVIS



#### **ADAPTIVE CORRIDORS IN LATHAM SQUARE Oakland, California**

[cltc.ucdavis.edu/publication/adaptive-corridors-latham-square](http://cltc.ucdavis.edu/publication/adaptive-corridors-latham-square)

*Energy savings can be achieved in corridors and other secondary spaces with an occupancy-based adaptive lighting system. Such a system is generally composed of occupancy sensors, dimmable light sources and a communication platform. The system automatically lowers light levels during vacancy and raises light output to the recommended level for occupant comfort during occupied periods. The adaptive lighting system installed at the Latham Square office building, located in Oakland, California, is based on Lutron's Energi TriPak solution, a stand-alone platform for adaptive lighting that employs cost-effective wireless control devices and programmable dimming ballasts.*

*The new 64W fluorescent light fixtures installed for this project are equipped with dimmable ballasts. Lutron occupancy sensors were installed throughout the corridors to provide adequate passive infrared sensor coverage for the corridor areas and each point of entry. The wireless sensors work in tandem with dimming modules, which control the light levels of the fixtures.*







## APPENDIX

---

# GLOSSARY

## A

---

**Accent or display lighting:** Lighting provided by directional light sources to illuminate specific areas or objects, such as display merchandise. Accent lighting sources can be recessed, surface mounted or mounted to a pendant, stem or track.

**Ambient or general lighting:** Lighting provided by non-directional light sources to provide low-level illumination for comfortable navigation through spaces. Ambient lighting is generally supplemented by **task lighting** and **accent lighting**.

**Astronomical time-switch control:** An automatic lighting control device that switches lights ON or OFF at specified times of the day or at times relative to astronomical events, such as sunset and sunrise. These devices can account for geographic location and calendar date and are commonly used in daylight harvesting applications.

## B

---

**Beam angle:** Also known as **beam spread**, the width of the cone of light emitted from a light source, defined from the center of the beam to the angle where the intensity of light is half of its maximum. Narrow beam angles create a spotlight effect, while broader beam angles spread light more evenly across a larger area.

## C

---

**Candela (cd):** Unit of measurement for luminous intensity. One candela (cd) is equal to one lumen per steradian (lm/sr). A candle flame emits light with a luminous intensity of approximately one candela.

**Case lighting:** Lighting designed for enclosed cases, such as glass display cases that display jewelry, electronics or other valuable items.

**Center beam candlepower (CBCP):** Luminous intensity at the center of the beam from a reflector lamp, such as a parabolic aluminized reflector (PAR) lamp. CBCP is measured in candelas (cd).

**Ceramic metal halide (CMH):** A type of high-intensity discharge (HID) lamp commonly used in retail lighting, particularly high- and low-bay applications. Like **metal halide** lamps, CMH lamps generate light using a mixture of argon, mercury and metal halide vapors. CMH lamps are a newer variation of MH capable of producing white light with a CRI as high as 96. Full light output takes about 2–10 minutes, making them less compatible with adaptive lighting controls. They can produce energy savings of up to 90% when replacing incandescent sources.

**Chandelier:** A ceiling-mounted luminaire that uses glass, crystal, ornamental metals or other decorative materials. A chandelier may be mounted close to the ceiling or suspended. Typically used as a significant element of interior architecture.

**Color Rendering Index (CRI):** A color fidelity metric for light sources based on chromaticity shifts of selected color samples compared to daylight for high CCT sources and incandescent light for low CCT sources.

**Compact fluorescent lamp (CFL):** A type of fluorescent lamp shorter than 9 inches in overall length with a T5 glass tube (or smaller diameter) folded, bent or bridged to create a compact shape.

**Correlated Color Temperature (CCT):** Measured in Kelvins (K), CCT indicates the warmth or coolness of light emitted from a lamp. Low CCT indicates a warmer (more red) hue while high CCT denotes a cooler (more blue) appearance. Sources with a CCT of 2,700–3,000K emit incandescent-like light while lamps with cooler color temperatures, such as 5,000–6,500K, are often chosen to approximate bright daylight on a clear afternoon.

**Countdown timer switch:** A device featuring one or more preset countdown time periods that turns lighting (or other loads) ON when activated and automatically switches OFF when the selected time period elapses.

## D

---

**Daylight control:** An automatic lighting control device that uses one or more photosensors to detect changes in daylight contribution and automatically adjust electric lighting levels accordingly. A **multi-level daylight control** adjusts the light output of the electric lighting system in either a series of steps or by continuous dimming in response to available daylight.

**Daylit Zone:** The floor area under skylights or next to windows. The Energy Code includes building and lighting control requirements for specific types of daylit zones, including Primary Sidelit, Secondary Sidelit and Skylit zones.

**Decorative Lighting:** Lighting provided for aesthetic purposes that is not meant to provide ambient, task or accent lighting.

**Dimmer:** A lighting control device that adjusts the light output of an electric lighting source by decreasing or increasing the power delivered to that system. **Step Dimmers** provide end users with one or more distinct light level settings (or steps) between maximum light output and OFF. **Continuous Dimmers** offer finer, more subtle control over a continuous range between maximum light output and the OFF setting.

## E

---

**Efficacy:** The amount of light produced by a lamp or luminaire relative to the amount of electrical power it consumes (lm/W). To calculate lamp efficacy, divide the lamp's rated initial lumens (lm) by the rated lamp power (watts) without including auxiliaries, such as ballasts, transformers and power supplies.

**Energy Management Control System (EMCS):** A computerized control system designed to regulate energy use by supporting monitoring and control of the operation of one or more building systems, such as lighting and HVAC. An EMCS can also be programmed to provide automated control based on signals from sensors or utilities.

## F

---

**Fluorescent:** A low-pressure mercury electric-discharge lamp in which a phosphor coating transforms some of the mercury ultraviolet energy into visible light.

---

## G

**General lighting:** See **ambient lighting**.

**GU24:** A lamp holder and socket configuration based on the International Energy Consortium coding system, where “G” stands for the broad type of two or more

projecting contacts (pins or posts), “U” distinguishes between lamp and holder designs of similar but not interchangeable types and “24” indicates 24 millimeters between the center points of the electrical contact posts.

---

## H

**High intensity discharge (HID) lamp:** An electric discharge lamp in which the light-producing arc is stabilized by bulb wall temperature. HID lamps include groups of lamps known as **mercury**, **metal halide** and **high pressure sodium**.

---

## I

**Illuminance:** A measure of the density of incident light output on a surface (i.e., lumens per area). The unit is lux (lx) when the area is measured in square meters and footcandle (fc) when the area is measured in square feet.

**Illumination:** Density of light incident at a point on a surface, measured in footcandles (fc), perpendicular to the surface.

**Incandescent lamp:** An electric lamp in which a filament gives off light when heated by an electric current.

---

## L

**Lamp:** The lighting industry term for a light source, such as a light bulb or fluorescent tube.

**Light output:** The rate at which a light source emits visible light. This “flow rate” of light is measured as lumens through time and generally defines “light”, for purposes of lighting design and illuminating engineering. It is also referenced to as '**luminous flux**'.

**Lighting control system:** Technology consisting of two or more components and capable of providing full functionality for lighting control compliance.

**Light-emitting diode (LED):** A solid-state diode that is constructed to emit colored or white light. The acronym LED is often used to refer to an LED component, device or package.

**LED lamp:** An LED component, device or package and other optical, thermal, mechanical and electrical (control circuitry) components with an integrated LED driver (power source) and a standardized base that is designed to connect to the branch circuit via a standardized base, lamp holder or socket.

**LED luminaire:** A complete lighting unit consisting of LED-based light-emitting elements and a matched driver together with parts to distribute light, to position and protect the light-emitting elements and to connect the unit to a branch circuit.

**Lumen:** The unit of measurement that describes the amount of light emitted from a light source. Higher lumen output indicates a brighter light source.

**Luminaire:** A light source consisting of a housing for lamp(s) and optics for specific light distributions.

**Luminance (L):** The intensity of light emitted from a light source or reflected off a surface, normalized by the area of the light source or the reflecting surface, projected on a plane vertical to the direction of view towards the light source or the surface (i.e., intensity or lumens per solid angle) per area. The units are Nit (cd/m<sup>2</sup>) and FootLambert (cd/ft<sup>2</sup>).

**Luminous flux:** The rate at which a light source emits visible light. This “flow rate” of light is measured as lumens through time and generally defines “light” for purposes of lighting design and illuminating engineering. It is also referred to as '**light output**'.

## M

---

**Mandatory Measures checklist:** A form used by the building plan checker and field inspector to verify a building's compliance with the prescribed list of Mandatory features, equipment efficiencies and product certification requirements. The documentation author indicates compliance by initialing, checking or marking N/A (for not applicable) in the boxes or spaces provided for the designer.

**Metal halide (MH):** A high-intensity discharge (HID) light source commonly used in retail, industrial and outdoor applications. MH lamps use a mixture of argon, mercury and metal halide. A hard outer glass covering absorbs much of the UV radiation emitted by MH lamps, thereby reducing their efficacy. Full light output takes about 2–10 minutes, making them less compatible with adaptive lighting controls. MH lamps produce more light than mercury vapor lamps and provide better color rendering, with CRI ratings of 60–96.

**Motion sensor:** A device that automatically changes the light level after an area is vacated to a pre-defined level. Motion sensor applies to outdoor lighting controls. When the device is used to control indoor lighting systems, it is called an occupant sensor, occupancy sensor, occupant sensing device or vacancy sensor.

**Multi-level lighting control:** A lighting control device that adjusts the output of electric lighting sources in multiple discrete steps.

**Multi-scene lighting control:** In addition to all-OFF, this feature allows end-users to program or select pre-defined lighting settings for two or more groups of luminaires for multiple activities or displays within a space.

## O

---

**Occupancy sensor:** A device that detects occupants, using motion or noise sensing as a proxy.

## P

---

**Pendant:** A luminaire that is suspended from the ceiling.

**Permanently installed lighting:** All luminaires attached to the inside or outside of a building site, including track and flexible lighting systems; lighting attached to walls, ceilings, columns, inside or outside of permanently installed cabinets, internally illuminated case work, mounted on poles, in trees or in the ground; lighting attached to ceiling fans and lighting integral to exhaust fans other than exhaust hoods for cooking equipment. Does not include portable lighting or lighting that is installed by the manufacturer in appliances.

**Photo controls:** Automated lighting controls based on the signal of one or more photosensors, usually used for daylight harvesting.

**Pin-base luminaire:** A luminaire, or fixture, that accepts lamps with a pin base. The pin base performs the same function as the screw base but with greater efficiency. GU-24 pin-base luminaires are meant to prevent the use of low-efficacy lamps in high-efficacy luminaires.

**Portable lighting:** Lighting that is not permanently installed or hardwired but uses a plug-in connection for electric power. (e.g., freestanding floor or table lamps, luminaires attached to modular furniture, workstation task lights, lights attached to workstation panels, movable displays and other impermanent luminaires) Requirements for portable lighting are covered by the Appliance Efficiency Regulations.

## R

---

**Readily accessible:** Capable of being reached quickly for operation, repair or inspection, without climbing or removing obstacles or resorting to using portable access equipment.



---

## S

**Screw-base luminaire:** A luminaire, or fixture, that accepts lamps with a screw base. (e.g., incandescent, CFL or LED replacement lamps)

**Skylight:** A daylight aperture on a roof having a slope of less than 60 degrees from the horizontal plane.

---

## T

**Task lighting:** Lighting designed to meet specific illumination needs for specific tasks.

**Track lighting:** An electric lighting system that utilizes luminaires mounted to a track, rail or cable.

**Time switch:** Also called a **timer switch** or **timer**, this device is designed to automatically control lighting based on the time of day.

---

## U

**Utility room:** A non-habitable room or building that contains only HVAC, plumbing or electrical controls or equipment (i.e., not a bathroom, closet, garage or laundry room).

---

## V

**Vacancy sensor:** An occupancy sensor that requires occupants to turn lights ON manually but automatically turns the lights OFF soon after an area is vacated. Also called a **manual-ON occupancy sensor** or **manual-ON/automatic-OFF sensor**.

---

## W

**Watt:** The International System of Units (SI) unit of power, equivalent to one joule per second, corresponding to the power in an electric circuit in which the potential difference is one volt and the current one ampere.

## APPENDIX

## TABLES

The original versions of the tables in this section can be found in the **2019 Energy Standards for Residential and Nonresidential Buildings**. These tables are used for determining what is required for compliance with the Energy Code and in the process of calculating lighting energy budgets.

**Table 140.6-B:**  
**Complete Building Method Lighting Power Density Values (W/ft<sup>2</sup>)**

Type of Use	Allowed Lighting Power
Assembly Building	0.7
Financial Institution Building	0.65
Industrial/Manufacturing Facility Building	0.6
Grocery Store Building	0.95
Gymnasium Building	0.65
Library Building	0.7
Healthcare Facility	0.9
Office Building	0.65
Parking Garage Building	0.13
Religious Facility Building	0.7
Restaurant Building	0.7
Retail Store Building	0.9
School Building	0.65
Sports Arena Building	0.75
Motion Picture Theater Building	0.7
Performing Arts Theater Building	0.8
All other buildings	0.4



**Table 140.6-C: Area Category Method — Lighting Power Density Values (W/ft<sup>2</sup>)**

Primary Function Area		Allowed Lighting Power Density for General Lighting (W/ft <sup>2</sup> )	Additional Lighting Power <sup>1</sup>	
			Qualified Lighting Systems	Additional Allowance (W/ft <sup>2</sup> , unless noted otherwise)
Auditorium Area		0.7	Ornamental	0.3
			Accent, display and feature <sup>3</sup>	0.2
Auto Repair or Maintenance Area		0.55	Detailed task work <sup>7</sup>	0.2
Audience Seating Area		0.6	Ornamental	0.3
Beauty Salon Area		0.8	Detailed task work <sup>7</sup>	0.2
			Ornamental	0.3
Civic Meeting Place Area		1.0	Ornamental	0.3
Classroom, Lecture, Training, Vocational Area		0.7	White or chalkboard <sup>1</sup>	4.5 W/ft
Commercial or Industrial Storage	Warehouse	0.45	—	—
	Shipping and Handling	0.6	—	—
Convention, Conference, Multipurpose and Meeting Area		0.85	Ornamental	0.3
Copy Room		0.5	—	—
Corridor Area		0.6	—	—
Dining Area	Bar or Lounge and Fine Dining	0.55	Ornamental	0.3
	Cafeteria or Fast Food	0.4		
	Family and Leisure	0.5		
Electrical, Mechanical, Telephone Rooms		0.4	Detailed task work <sup>7</sup>	0.2
Exercise or Fitness Center and Gymnasium Areas		0.5	—	—
Hotel Function Area		0.85	Ornamental	0.3
Museum Area	Exhibition or Display	0.6	Accent, display and feature <sup>3</sup>	0.5
	Restoration Room	0.75	Detailed task work <sup>7</sup>	0.2
Financial Transaction Area		0.8	Ornamental	0.3
General or Commercial and Industrial Work Areas	Low Bay	0.6	Detailed task work <sup>7</sup>	0.2
	High Bay	0.65	Detailed task work <sup>7</sup>	0.2
	Precision	0.85	Precision specialized work <sup>9</sup>	0.7
Library	Reading Area	0.8	Ornamental	0.3
	Stacks Area	1.1	—	—

**Table 140.6-C: Area Category Method — Lighting Power Density Values (W/ft<sup>2</sup>) Continued**

Main Entry Lobby		0.85	Ornamental	0.3
Locker Room		0.45	—	—
Lounge, Breakroom or Waiting Area		0.65	Ornamental	0.3
Concourse and Atria Area		0.9	Ornamental	0.3
Office Area	> 250 ft <sup>2</sup>	0.65	Portable lighting for office areas <sup>6</sup>	0.2
	≤ 250 ft <sup>2</sup>	0.7		
	Open plan office	0.6		
Parking Garage Area	Parking Zone	0.1	First ATM	100W
			Additional ATM	50W each
	Dedicated Ramps	0.25	—	—
	Daylight Adaptation Zones <sup>2</sup>	0.5	—	—
Pharmacy Area		1.1	Specialized task work <sup>8</sup>	0.35
Retail Sales Area	Grocery Sales	1.05	Accent, display and feature <sup>3</sup>	0.2
			Decorative <sup>4</sup>	0.15
	Retail Merchandise Sales	1.0	Accent, display and feature <sup>3</sup>	0.2
			Decorative <sup>4</sup>	0.15
	Fitting Room	0.6	External illuminated mirror <sup>5</sup>	40W each
			Internal illuminated mirror <sup>5</sup>	120W each
Theater Area	Motion picture	0.6	Ornamental	0.3
	Performance	1.0		
Kitchen or Food Preparation Area		0.95	—	—
Scientific Laboratory Area		1.0	Specialized task work <sup>8</sup>	0.35
Healthcare Facility and Hospitals	Exam or Treatment Room	1.15	—	—
	Imaging Room	1.0	—	—
	Medical Supply Room	0.55	—	—
	Nursery	0.95	Tunable white or dim-to-warm <sup>10</sup>	0.1
	Nurse's Station	0.75	Tunable white or dim-to-warm <sup>10</sup>	0.1
	Operating Room	1.9	—	—
	Patient Room	0.55	Decorative <sup>4</sup>	0.15
			Tunable white or dim-to-warm <sup>10</sup>	0.1
	Physical Therapy Room	0.85	Tunable white or dim-to-warm <sup>10</sup>	0.1
Recovery Room	0.9	Tunable white or dim-to-warm <sup>10</sup>	0.1	
Laundry Area		0.45	—	—
Religious Worship Area		0.95	Ornamental	0.3



**Table 140.6-C: Area Category Method — Lighting Power Density Values (W/ft<sup>2</sup>) Continued**

Restrooms		0.65	Accent, display and feature <sup>3</sup>	0.2
			Decorative <sup>4</sup>	0.15
Transportation Function	Baggage Area	0.4	—	—
	Ticketing Area	0.45	Accent, display and feature <sup>3</sup>	0.2
Sports Arena— Playing Area	Class I Facility <sup>13</sup>	2.25	—	—
	Class II Facility <sup>13</sup>	1.45	—	—
	Class III Facility <sup>13</sup>	1.1	—	—
	Class IV Facility <sup>13</sup>	0.75	—	—
Stairwell		0.5	Accent, display and feature <sup>3</sup>	0.2
			Decorative <sup>4</sup>	0.15
Videoconferencing Studio		0.9	Videoconferencing	1.0
All other		0.4	—	—
Aging Eye or Low-vision <sup>11</sup>	Main Entry Lobby	0.85	Ornamental	0.3
			Transition lighting OFF at night <sup>12</sup>	0.95
	Stairwell	0.8	—	—
	Corridor Area	0.8	Decorative <sup>4</sup>	0.15
	Lounge or Waiting Area	0.75	Ornamental	0.3
	Multipurpose Room	0.95	Ornamental	0.3
	Religious Worship Area	1.0	Ornamental	0.3
	Dining	0.8	Ornamental	0.3
Restroom	0.8	Accent, display and feature <sup>3</sup>	0.2	

Footnotes for this table are listed below:

1. Whiteboard or chalkboard — directional lighting dedicated to a whiteboard or chalkboard.
2. Daylight Adaptation Zones shall be no longer than 66 feet from the entrance to the parking garage.
3. Accent, display and feature lighting — luminaires shall be adjustable or directional.
4. Decorative lighting — primary function shall be decorative and not to provide general lighting.
5. Illuminated mirrors — lighting shall be dedicated to the mirror.
6. Portable lighting in office areas includes under shelf or furniture-mounted supplemental task lighting qualifies when controlled by a time clock or an occupancy sensor.
7. Detailed task work — lighting provides high level of visual acuity required for activities with close attention to small elements or extreme close up work.
8. Specialized task work — lighting provides for small-scale, cognitive or fast performance visual tasks; lighting required for operating specialized equipment associated with pharmaceutical or laboratorial activities.
9. Precision specialized work — lighting for work performed within a commercial or industrial environment that entails working with low contrast, finely detailed or fast moving objects.
10. Tunable white luminaires capable of color change greater than or equal to 2,000K CCT, or dim-to-warm luminaires capable of color change greater than or equal to 500K CCT, connected to controls that allow color changing of the luminaires.
11. Aging Eye and low-vision areas can be documented as being designed to comply with the light levels in ANSI/IES RP-28 and are or will be licensed by local or state authorities for either senior long-term care, adult day care, senior support and people with special visual needs.
12. Transition lighting OFF at night. Lighting power controlled by astronomical time clock or other control to shut OFF lighting at night. Additional LPD only applies to area within 30 feet of an exit. Not applicable to lighting in daylight zones.
13. Class I Facility is used for competition play for 5,000 or more spectators. Class II Facility is used for competition play for up to 5,000 spectators. Class III Facility is used for competition play for up to 2,000 spectators. Class IV Facility is normally used for recreational play and there is limited or no provision for spectators.

**Table 140.6-D: Tailored Method Lighting Power Allowances**

Primary Function Area	General Illumination Level (lux)	Wall Display Lighting Power Density (W/ft)	Allowed Combined Floor Display Power and Task Lighting Power Density (W/ft <sup>2</sup> )	Allowed Ornamental and Special Effect Lighting Power Density (W/ft <sup>2</sup> )
Auditorium Area	300	3.00	0.2	0.4
Convention, Conference, Multipurpose and Meeting Center Areas	300	2.00	0.35	0.4
Dining Areas	200	1.25	0.5	0.4
Exhibit and Museum Areas	150	11.5	0.8	0.4
Hotel Area				
Ballroom and Events	400	1.8	0.12	0.4
Lobby	200	3.5	0.2	0.4
Main Entry Lobby	200	3.5	0.2	0.4
Religious Worship Area	300	1.30	0.4	0.4
Retail Sales				
Grocery	600	6.8	0.7	0.4
Merchandise Sales and Showroom Area	500	11.8	0.8	0.4
Theater Area				
Motion Picture	200	2.00	0.2	0.4
Performance Arts	200	7.5	0.2	0.4

**Table 140.6-E: Tailored Wall and Floor Display Mounting Height Adjustment Factors**

Height in feet above finished floor and bottom of luminaire(s)	Floor Display or Wall Display Mounting Height Adjustment Factor
< 10'-7"	1.00
10'-7" to 14'-0"	0.85
> 14'-0" to 18'-0"	0.75
> 18'-0"	0.7

**Table 140.6-F: Room Cavity Ratio (RCR) Equations**

Determine the Room Cavity Ratio for Table 140.6-G using one of the following equations	
Room cavity ratio for rectangular rooms:	Room cavity ratio for irregularly shaped rooms:
$RCR = \frac{5 \times H \times (L + W)}{L \times W}$	$RCR = \frac{2.5 \times H \times P}{A}$

*H = Vertical distance from the work plane to the center line of the lighting fixture  
 L = Length      W = Width      P = Perimeter      A = Area of the room*

**Table 140.6-G: Tailored Method General Lighting Power Allowed—By Illuminance and Room Cavity Ratio**

General Illuminance Level (lux) <sup>1</sup>	General Lighting Power Density (W/ft <sup>2</sup> ) for the following RCR values <sup>2</sup>			
	RCR ≤ 2.0	RCR > 2.0 and ≤ 3.5	RCR > 3.5 and ≤ 7.0	RCR > 7.0
150	0.4	0.45	0.6	0.75
200	0.45	0.55	0.75	1.0
300	0.65	0.8	1.0	1.4
400	0.75	0.95	1.25	1.5
500	0.9	1.05	1.45	1.85
600	1.08	1.24	1.64	2.38

<sup>1</sup> Illuminance values from Column 2 of Table 140.6-D.  
<sup>2</sup> RCR values are calculated using applicable equations in Table 140.6-F.

---

**APPENDIX**

---

# RESOURCES

## COMPLIANCE RESOURCES

---

### BUILDING ENERGY EFFICIENCY STANDARDS

[www.energy.ca.gov/programs-and-topics/programs/building-energy-efficiency-standards/2019-building-energy-efficiency](http://www.energy.ca.gov/programs-and-topics/programs/building-energy-efficiency-standards/2019-building-energy-efficiency)

Visit the Energy Commission website to download the Building Energy Efficiency Standards for Nonresidential Buildings. The Energy Code should be the first resource for any contractor, builder or designer with questions about the Energy Code regulations. Supporting documents and information on how to obtain public domain software for compliance are also available. The 2019 Nonresidential Compliance Manual and 2019 Nonresidential Alternative Calculation Method Reference Manual are among the related documents provided.

### CALIFORNIA ENERGY COMMISSION MODERNIZED APPLIANCE EFFICIENCY DATABASE SYSTEM

[cacertappliances.energy.ca.gov/Login.aspx](http://cacertappliances.energy.ca.gov/Login.aspx)

This online database features Quick Search and Advanced Search options that allow users to easily verify if lighting products have been certified to the Energy Commission as meeting applicable efficiency standards.

### APPLIANCE EFFICIENCY REGULATIONS

[www.energy.ca.gov/rules-and-regulations/appliance-efficiency-regulations-title-20/appliance-regulations-certification](http://www.energy.ca.gov/rules-and-regulations/appliance-efficiency-regulations-title-20/appliance-regulations-certification)

Energy efficiency and performance standards for appliances, including ballasts, lamps, luminaires and lighting controls, are detailed in the Appliance Efficiency Regulations. This and other resources are available through the Energy Commission's website.

### ENERGY CODE ACE

[energycodeace.com](http://energycodeace.com)

This site developed by the California Statewide Codes & Standards Program provides free tools, trainings and resources to help users meet the latest Energy Code and Appliance Efficiency Regulations requirements. Visitors can download fact sheets, trigger sheets, checklists and information on classes (online or in-person) and workshops.

### CALIFORNIA LIGHTING TECHNOLOGY CENTER

[cltc.ucdavis.edu](http://cltc.ucdavis.edu)

The California Lighting Technology Center (CLTC) was established through joint efforts by the Energy Commission and the University of California, Davis. CLTC develops and tests state-of-the-art, energy-saving lighting and daylighting innovations. CLTC also offers training and educational programs on energy-efficient lighting.

### NATIONAL LIGHTING CONTRACTORS ASSOCIATION OF AMERICA (NLCAA)

[nlcaa.org](http://nlcaa.org)

NLCAA, Inc. is a non-profit organization approved by the Energy Commission to implement the training and certification of Acceptance Test Technicians in order to serve a critically important function for ensuring high-quality installation of energy efficiency lighting controls systems in California nonresidential lighting.



## DESIGNLIGHTS CONSORTIUM QUALIFIED PRODUCTS LIST

[designlights.org/qpl](https://designlights.org/qpl)

This online database of quality, high-efficiency LED products for the commercial sector is maintained by the DesignLights Consortium, a project of the regional non-profit Northeast Energy Efficiency Partnerships. It allows users to search for LED products by criteria (such as CRI and light output), categories (including display case lighting and track lighting), manufacturer or keyword. Products listed may or may not qualify for certification to the Energy Commission.

## CALIFORNIA ADVANCED LIGHTING CONTROLS TRAINING PROGRAM (CALCTP)

[calctp.org](https://calctp.org)

CALCTP educates, trains and certifies licensed electrical contractors and state-certified general electricians in the proper installation, programming, testing, commissioning and maintenance of advanced lighting control systems.

## ENERGY CODE HOTLINE

**Toll-free in California: (800) 772-3300, [title24@energy.ca.gov](mailto:title24@energy.ca.gov)**

The Energy Code Hotline is a resource for any questions regarding the Energy Code. The hotline is available Monday through Friday, 8 A.M.–12 P.M. and 1–4:30 P.M.

## CLASSES

### CALIFORNIA ASSOCIATION OF BUILDING ENERGY CONSULTANTS

[cabec.org/title-24](https://cabec.org/title-24)

### BUILDING OPERATOR CERTIFICATION CALIFORNIA TRAINING SCHEDULE

[theboc.info/ca/ca-schedule.html](https://theboc.info/ca/ca-schedule.html)

### BUILDING OWNERS AND MANAGERS ASSOCIATION ONLINE EDUCATION SCHEDULE

[boma.org/education](https://boma.org/education)

### WORKSHOP & EVENT CALENDAR FOR THE CENTER FOR SUSTAINABLE ENERGY, CALIFORNIA

[energycenter.org/events](https://energycenter.org/events)

## MANUFACTURER TRAINING CENTERS

### ACUITY BRANDS ACUITY ACADEMY

Berkeley, CA

[www.acuitybrands.com/acuityacademy](https://www.acuitybrands.com/acuityacademy)

### EATON'S COOPER LIGHTING BUSINESS

Online Design Center

[cooperindustries.com/content/public/en/resources/education.html](https://cooperindustries.com/content/public/en/resources/education.html)

### LUTRON EXPERIENCE CENTER

California Experience and Training Center

Irvine, CA

[lutron.com/en-US/Experience-Light-Control/Pages/Inspiration/ExperienceCenter.aspx](https://lutron.com/en-US/Experience-Light-Control/Pages/Inspiration/ExperienceCenter.aspx)

## UTILITY EDUCATION & DEMONSTRATION CENTERS

All or most of these California utility centers host lighting classes for Energy Code compliance. They also house lighting technology demonstration spaces and tool lending libraries that can provide visitors with energy and light meters, data loggers, lighting design software, lighting design manuals and other resources.

Online calendars list training events and workshops. Some websites offer virtual video tours of the demonstration centers and information on resources and services. Visitors and class participants can also learn about the utilities' rebate and incentive programs.

### PACIFIC GAS AND ELECTRIC COMPANY (PG&E)

[pge.com](https://pge.com)

Pacific Energy Center (PEC), San Francisco  
Energy Training Center, Stockton

### SACRAMENTO MUNICIPAL UTILITY DISTRICT

[smud.org](https://smud.org)

Energy & Technology Center, Sacramento

### SAN DIEGO GAS & ELECTRIC

[sdge.com](https://sdge.com)

Energy Innovation Center, San Diego

### SOUTHERN CALIFORNIA EDISON (SCE)

[sce.com](https://sce.com)

Energy Education Centers  
Irwindale, Tulare and on-location in other cities



**CALIFORNIA LIGHTING TECHNOLOGY CENTER  
UNIVERSITY OF CALIFORNIA, DAVIS**

633 Peña Drive  
Davis, CA 95618  
Phone: (530) 747-3838  
Fax: (530) 747-3812  
Email: [cltc@ucdavis.edu](mailto:cltc@ucdavis.edu)

For more information and resources about the Energy Code, visit the CLTC website at [cltc.ucdavis.edu](http://cltc.ucdavis.edu).

8/2020

